

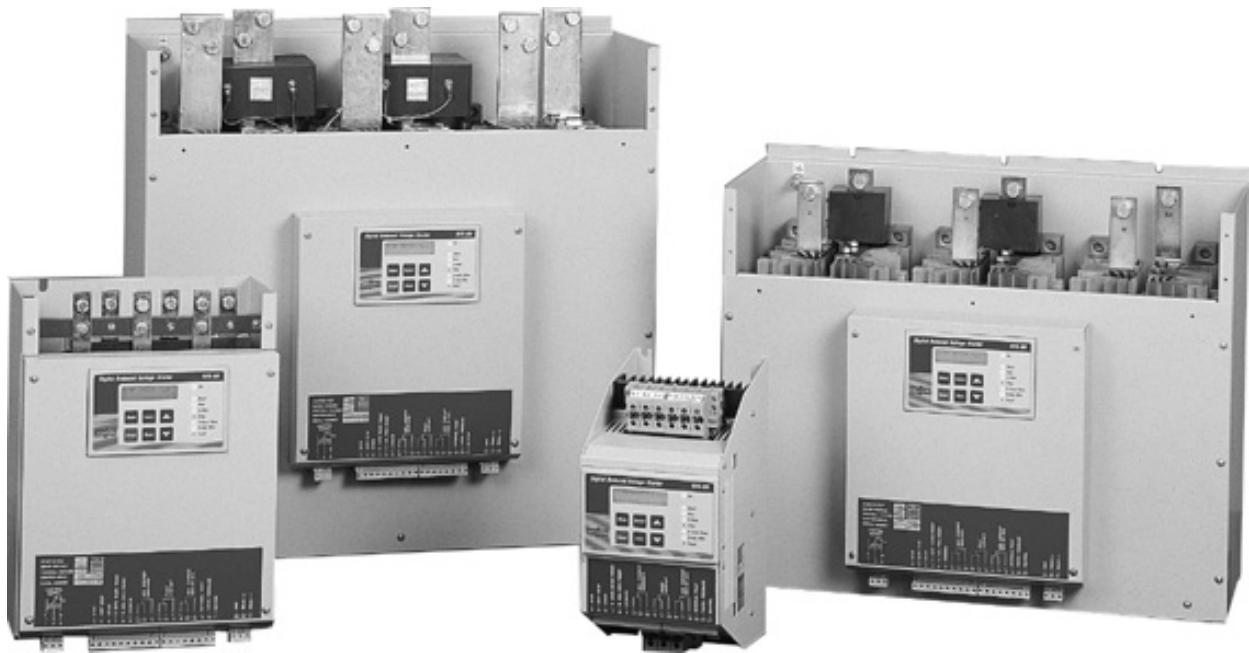

RVS-DN

Digital Soft Starter
8-3500A, 220-1000V



Instruction Manual
Ver. 12/10/2003



Table of Contents

| Page | Subject | Appendix Page | Subject |
|-------|---------------------------------------|---------------|---|
| 1 | Starter Selection | 39 | Table of content |
| 2 | Installation | 40 | UL and cUL instructions, LR recommendations |
| 3 | By-pass contactor | 41 | Fuse selection |
| 4 - 6 | Control terminals | 42 | Motor and Starter Fault Occurrence Timing Table |
| 7 | Control terminals – Option Boards | 43 | Warranty claim sheet & Fault Inquiry |
| 8 | Control Wiring | 44 | Inside Delta Description |
| 9-11 | Wiring Diagrams | 45 | Overload Trip Time (Approximate calculation) |
| 12-13 | Wiring Diagrams – Communication | 46-50 | Dimensions and Weights |
| 14 | Wiring Diagrams – Diesel Generator | 51 | Block Diagram and Notes |
| 15 | Wiring Diagrams – Brake motor | 52 | Ordering Information |
| 16-17 | Internal setting | | |
| 18-19 | Start and stop parameters | | |
| 20-21 | Motor and starter protection | | |
| 22-23 | Front panel and LCD Displays | | |
| 24 | Display mode and Default Parameters | | |
| 25-30 | Parameter setting | | |
| 31-32 | Start-up and Pump Control adjustments | | |
| 33-34 | Menu Description | | |
| 35-36 | Trouble shooting | | |
| 37-38 | Technical specification | | |

Safety



- Read this manual carefully before operating the equipment and follow its instructions
- Installation, operation and maintenance should be in strict accordance with this manual, national codes and good practice. Installation or operation not performed in strict accordance with these instructions will void manufacturer's warranty.
- Disconnect all power inputs before servicing the soft-starter and/or the motor.
- After installation, check and verify that no parts (bolts, washers, etc) have fallen into the power Section (IP00 for sizes B-G).

Attention

- This product was designed for compliance with IEC 947-4-2 for class A equipment.
- RVS-DN 8 - 820 are UL approved. RVS-DN 950 - 3500 are designed to meet UL requirements.
- RVS-DN 8 - 1400 are LR approved. RVS-DN 1800 - 3500 are designed to meet LR requirements.
- Use of the product in domestic environments may cause radio interference, in which case, the user may be required to employ additional mitigation methods.
- Utilization category is AC-53a or AC53b. Form1. For further information, see Technical Specifications for further details.

Warnings



- Internal components and P.C.B's are at main potential when the RVS-DN is connected to main. This voltage is extremely dangerous and will cause death or severe injury if contacted.
- When RVS-DN is connected to main, even if control voltage is disconnected and motors is stopped, full voltage may appear on starter's output and motor's terminals.
- Unit must be grounded to ensure correct operation, safety and to prevent damage.
- Check that Power Factor capacitors are not connected to the output side of the soft starter.

The company reserves the right to make any improvements or modifications to its products without prior notice.

Starter Selection

The RVS-DN is a highly sophisticated and reliable starter designed for use with standard three-phase, three-wire, squirrel cage induction motors. It provides the best method of reducing current and torque during motor starting.

The RVS-DN starts the motor by supplying a slowly increasing voltage to the motor, providing soft start and smooth acceleration, while drawing the minimum current necessary to start the motor.

The second generation, microprocessor based digital circuitry provides unique features like pump control, slow speed, electronic reversing and accurate motor protection, with optional Insulation Protection, Thermistor input, etc.

The optional RS 485 Communication with MODBUS protocol enables full control (Start, Stop, Dual Adjust, command, etc.) and supervision. Up to 32 starters can be connected on a shield twisted pair to a host computer.

RVS-DN Ratings and Frame sizes

| Max Motor FLA (Amp) | Starter Type (FLC) | Frame Size |
|---------------------|--------------------|------------|
| 8 | RVS-DN 8 | A |
| 17 | RVS-DN 17 | |
| 31 | RVS-DN 31 | |
| 44 | RVS-DN 44 | |
| 58 | RVS-DN 58 | |
| 72 | RVS-DN 72 | |
| 85 | RVS-DN 85 | B |
| 105 | RVS-DN 105 | |
| 145 | RVS-DN 145 | |
| 170 | RVS-DN 170 | |
| 210 | RVS-DN 210 | C |
| 310 | RVS-DN 310 | |
| 390 | RVS-DN 390 | |
| 460 | RVS-DN 460 | D |
| 580 | RVS-DN 580 | |
| 820 | RVS-DN 820 | |
| 950 | RVS-DN 950 | |
| 1100* | RVS-DN 1100 | E |
| 1400* | RVS-DN 1400 | |
| 1800* | RVS-DN 1800 | |
| 2150* | RVS-DN 2150 | F |
| 2400* | RVS-DN 2400 | G |
| 2700* | RVS-DN 2700 | |
| 3000* | RVS-DN 3000 | |
| 3500* | RVS-DN 3500 | |

* Fully rated when used with a by-pass contactor

Dimensions (mm)

For exact dimensions, see Dimension Sheets.

| Size | Width | Height | Depth | Weight (Kg) |
|--------|-------|--------|-------|---------------|
| A | 153 | 310 | 170* | 4.5, 6.0, 7.5 |
| B std. | 274 | 370 | 222 | 15 |
| B new | 274 | 385 | 238 | 15 |
| C | 590** | 500 | 290 | 45 |
| D | 623 | 660*** | 290 | 65 |
| E | 723 | 1100 | 370 | 170 |
| F | 750 | 1300 | 392 | 240 |
| G | 900 | 1300 | 410 | 314 |

* 217mm – for 44, 58 & 72A

** 536mm – By special order, without side covers

*** Add 160mm for bypass bus-bars extension

The starter should be selected in accordance with the following criteria (see Ordering Information data).

Motor Current & Starting Conditions

Select the starter according to motor's Full Load Ampere (FLA) – as indicated on its nameplate (even if the motor is not fully loaded).

The RVS-DN is designed to operate under the following conditions:

Max. ambient temp: 50°C
 Max. starting current: 400% motor's FLA
 Max. starting time: 30 sec. (at 400% FLA)
 Max. starts per hour: 4 starts per hour at max conditions. Up to 60 starts per hour at light load applications.

Note: For very frequent starts (inching applications), the inching current should be considered as the Full Load Ampere (FLA).

Main Voltage (line to line)

Thyristor's PIV rating, internal circuitry and insulation defines four voltage levels: 220-440V, 575-600V, 460-500V, 660-690V

Each starter is suitable for one of the above levels & for 50/60 Hz.

Control Voltage

The Control Voltage operates the electronic circuitry and fans. Two voltage levels are available:

220-240V + 10%-15%, 50/60 Hz (standard)
 110-120V + 10%-15%, 50/60 Hz
 110 Vdc for Frame size B-G (by special order).

Control Inputs

Control Input voltage (start, stop, etc.) can be the same as Control Supply above (standard), or 24-240V AC / DC (by special order).

Options (see Ordering Information Data)

- Communication Card (option # 3)
- Insulation Tester Card (option # 4)
- Analogue card-Thermistor in/Analogue out (option # 5)
- Special treatment – Consult factory (option # 8)
- Preparation for by-pass contactor (option # 9)
- Special width for size C-536 mm (option #A)
- Line/load bus-bars at the bottom, size C&D (option #B)
- Door install MMI instead of the original (option #D)
- Door install MMI w/op.#L&1.5m cable (option #DK)
- Back-lit LCD (option # L)
- Lloyds Register ENV-1, ENV-2 approval (option #M)
- Tachometer feedback (option # T)
- UL & cUL approvals (option # U)

Installation

Prior to Installation

Check that Motor's Full Load Ampere (FLA) is lower than or equal to the starters Full Load Current (FLC) and that Main and Control voltages are as indicated on the front panel.

Mounting

- The starter must be mounted vertically, allow sufficient space above and below the starter for suitable airflow.
- It is recommended to mount the starter directly on the rear metal plate for better heat dissipation.
- Do not mount the starter near heat sources.
- Protect the starter from dust and corrosive atmospheres.

Note: For harsh environments, it is recommended to order the starter with Option # 8 – Special Treatment (printed circuit board coating).

Temp. Range and Heat Dissipation

The starter is rated to operate over a temperature range of -10°C (14°F) to + 50°C (122°F). Relative non-condensed humidity inside the enclosure should not exceed 95%.

Starter's heat dissipation is approx. 3 x In (three times the current in watts).

Example: For a 100A motor, heat dissipation is approx. 300 watts.

Internal enclosure heating can be reduced through the use of:

- Additional ventilation
- Employing a by-pass contactor.

Additional Ventilation

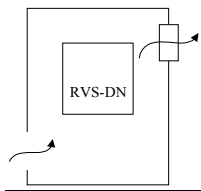

General purpose enclosure
Fan on air outlet

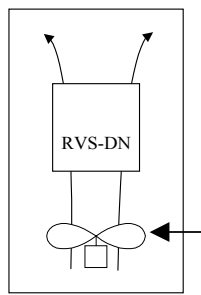

Non-ventilated enclosure
Fan, creating air circulation

Fan

Calculating the enclosure size, for non-ventilated metallic enclosure:

$$\text{Area (m}^2\text{)} = \frac{0.12 \times \text{Total heat dissipation (Watts)*}}{60 - \text{External ambient temp. (}^\circ\text{C)}}$$

Where Area (m²) - Surface area that can dissipate heat (front, sides, top).

* Total heat dissipation of the starter and other control devices in the enclosure.

Note: If the starter is installed in a non-metallic enclosure, a by-pass contactor must be used.

Short Circuit Protection

Protect the starter against a short circuit by Thyristor Protection Fuses (see appendix page 44 for I₂t and fuses).

Transient Protection

Line transient voltages can cause a malfunction of the starter and damage to the thyristors. Starters frame sizes B-E incorporate Metal Oxide Varistors (MOV) to protect from normal line voltage spikes.

For size A, or when higher transients are expected, additional external protection should be used (consult factory).

ATTENTION

When Start signal is initiated and a motor is not connected to load terminals, the Wrong Connection protection will be activated.

WARNING

1. When main voltage is connected to the RVS-DN, even if control voltage is disconnected, full voltage may appear on the starter load terminals. Therefore, for isolation purposes, it is necessary to connect an isolating device before the starter.
2. Power factor correction capacitors must not be installed on the starters load side. When required, install capacitors on starter's line side.

WARNING

RVS-DN current transformers, although may be installed outside of the soft-starter with extended wires, can not be grounded or connected to any other load except for the RVS-DN itself. Any such connection may cause damage to the load which was connected to it or to the RVS-DN itself!

By-pass Contactor

Under normal operating conditions, the heat dissipated by an electronic soft starter causes heating of the enclosure and energy losses. The heating and losses can be eliminated by the use of a by-pass contactor, which by passes the RVS-DN after completion of start-up, so motor current will flow through the by-pass contactor.

In this case the starter protection will be maintained except for the current protection, as the current will not flow through the internal current transformers after the by-pass closes.

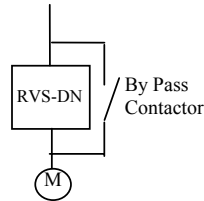

Preparation for By-pass Contactor (option)

In order to maintain current protection after the by-pass contactor closes, Preparations for By-pass Contactor can be ordered.

Frame Size A (8 – 72A)

Must be factory supplied, three additional terminals are added, marked L_{1b}, L_{2b}, L_{3b}. These terminals are connected after the internal C/Ts, intended for connection to the by-pass.

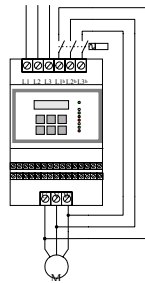

Frame Sizes B (Standard and New 85-170A)

Old – Additional set of bus-bars can be field mounted on the line side, after the C/Ts, marked L_{1b}, L_{2b}, L_{3b}.

New – Additional set of bus bars is built-in, where the line side is on top and motor side is at the bottom with the by-pass

L_{1b}, L_{2b}, L_{3b} terminals are located. By-pass contactor cables should be connected to these terminals.

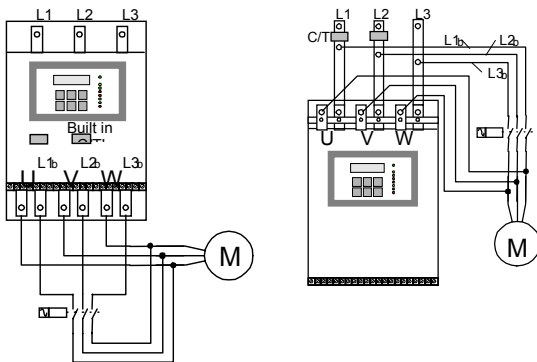

Frame Size C (210 - 390A)

Additional set of bus bars can be field mounted on line side, after the C/T's marked L_{1b}, L_{2b}, L_{3b}. Bypass cables should be connected to these terminals.

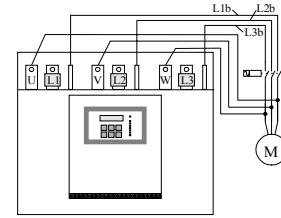

Frame Size D (460 - 820A)

Additional set of bus bars can be field mounted on line side, downstream to the C/T's marked L_{1b}, L_{2b}, L_{3b}. Bypass cables should be connected to these bus-bars.

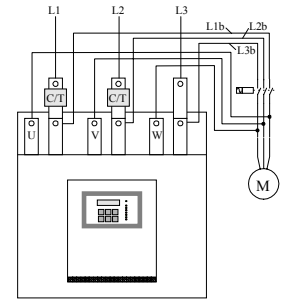

Note: Starter frame sizes C and D can be field modified to have Line and Load Bus-bars at the bottom (consult factory for further information).

Frame Size E (1100 – 1800A)

Frame Size F (2150A)

Frame Size G (2400 – 3500A)

Additional set of bus-bars can be field mounted on line side, down stream to the C/Ts, marked L_{1b}, L_{2b}, L_{3b}. Bypass cables should be connected to the bus-bars down stream to the C/T's

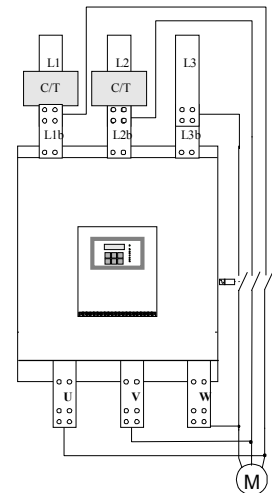

Note: Connect as follows

- **Line to L1, L2, L3**
- **By-pass**
Input to L_{1b}, L_{2b}, L_{3b}
Output to U, V, W
- **Motor (Load) to U, V, & W**

Do not interchange line and load connections.

Control Terminals

Control Supply **Terminals 1-3**
 110-120VAC or 220-240VAC, 50/60Hz as indicated on the front panel, required to power the electronic circuitry and fans when incorporated. This voltage can be from a grounded or ungrounded main system.

110VDC can be supplied by special order for starter sizes B-G (not field interchangeable).

Note: It is recommended that terminals 1-3 be always connected to the Control Supply.

Fan's Supply Voltage **Terminal 2**
 An internal jumper, connected between fan and terminal 2 enables three modes of operation (see Fan Control – page 16). For fan power consumption, see technical specification.

Continuous mode (factory default) – Fan operates as long as Control Supply is connected to terminals 1-3. Leave internal jumper connected to left lug of J1 terminal (A).

External control mode – Fan operates when Control Supply is connected to terminal 2. Connect internal jumper to the center lug of J1 terminal (B). For use without by-pass, connect fans before “start” and disconnect at least 5 minutes after “Stop/Soft-stop”.

Automatic mode – Fan begins operation when start signal is initiated and stops approximately five minutes after start signal. When stop signal is initiated, the fan begins operation and stops after five minutes. Connect internal jumper right lug of J1 terminal (C).

WARNING
 Automatic mode may be used only if by-pass contactor is directly controlled by the RVS-DN “End-of-Acceleration” contact.

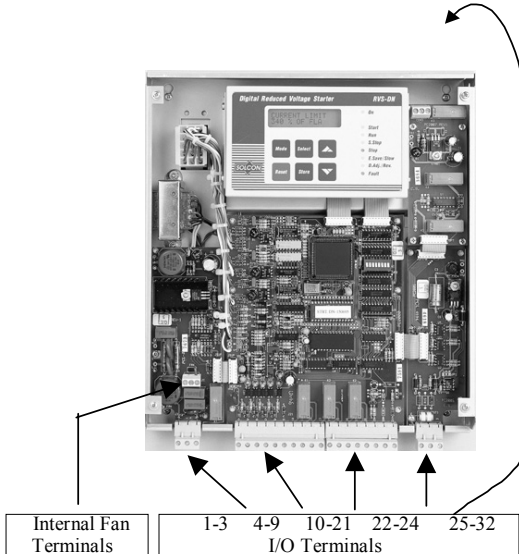

Control Inputs
 Incorporating opto-couplers to isolate the micro-processor circuitry.
 The starter is supplied standard for 220-240V, 50/60Hz Control Supply and Control Inputs voltage.

By special order, Control Inputs may be supplied for voltage levels of 24-240 VAC/DC. (for more information, see Ordering Information data – Appendix page 48).

Stop **Terminal 4**
 Input from a N.C contact. To stop the motor, disconnect control voltage from Terminal 4 for at least 250mSec.

Soft stop **Terminal 5**
 Input from a N.C contact. To soft stop the motor, disconnect control voltage from Terminal 5 for at least 250mSecs.

Note: If Soft Stop is not required, connect a jumper between terminals 4 and 5.

Start **Terminal 6**
 Input from a N.O contact. To start the motor, connect control voltage to Terminal 6 for at least 250mSecs.

- Notes:**
1. Motor will start only if Stop (4) and Soft Stop (5) terminals are connected to control voltage.
 2. Reset after a fault is not possible for as long as Start command is present.

Energy Save / Slow Speed / Reset **Terminal 7**
 Input from a N.O contact. Selection between above functions is made from the keypad or through the communication (see I/O Programm.)

- When Energy Save function is selected –connect terminal 7 to control voltage by a jumper for automatic operation, upon load decrease. When connected through a N.O contact, closing the contact operates Energy Save.
- When Slow Speed function is selected – connect control voltage to terminal 7 **before** starting, to run the motor at 1/6 nominal speed. Closing terminal 7 while motor is running will not have any effect.
- When Reset function is selected, connect terminal 7 to control voltage (use a N.O momentary contact) to reset the starter.

Control Terminals

Dual Adjust Reverse / Reset Terminal 8

Input from a N.O contact. Selection between above functions is made from the keypad or through the communication (see I/O Programming).

a. When Dual Adjustment function is selected – connect terminal 8 to control voltage to operate starter with the Dual adjustment characteristic. Switching between primary and Dual Adjustment settings can be done before and during starting. If a push-button arrangement is used, keep control voltage connected at least RUN LED is lit.

Note: When starting from Diesel Generator or weak power supply set dip. Switch # 3 “On” – connect terminal 8 to control voltage to operate starter with Generator Parameter settings.

b. When Slow Speed reverse function is selected (Slow Speed function must be selected for terminal 7 and Control Input voltage connected to it). Connect control voltage to terminal 8 to reverse direction. Reverse command can be given before motor is started, or during operation at Slow Speed. Connecting Control Voltage to terminal 8 before motor is started, starts the motor in Reverse Direction. Connecting control voltage while motor is running at Slow Speed, stops the motor for 0.6 – 2 sec (according to motor size) before reversing its direction.

c. When “Reset” function is selected, connect terminal 8 to control voltage (use a N.O momentary contact) to reset the starter.

Common Terminal 9

Common for terminals 4, 5, 6, 7, 8.

Note: When Control Supply and Control Input voltage are from the same source, connect a jumper between terminals 3 and 9.

Immediate/Shear-pin Relay Terminals 10-11-12

Terminals: 10- N.O. 11-N.C. 12 – common.

Voltage free 8A, 250VAC, 2000VA max.

Selection between functions is made from the keypad or through the communication, (see I/O Programming).

Programmable functions:

1. Immediate (after start signal).

When immediate is selected, the contact changes its position upon Start signal. The contact returns to its original position on Stop signal, in case of a fault or upon control supply outage.

When Soft Stop is operated, the contact returns to the original position at the end of the Soft Stop process.

The contact incorporates On & Off delays 0-60 sec. each.

The Immediate Contact can be used:

- To release the brake of a brake motor.
- For interlocking with other systems.
- For signaling.
- Used with delay for opening an upstream contactor at the end of soft stop thus, allowing current decrease to zero before opening the contactor.
- To switch to / from Dual Adjustment settings with a time delay from Start signal (see Special Starting).

2. O/C Shear-pin detection

When O/C Shear-pin is selected, the contact changes position upon Shear-pin detection (Starter’s trip can be delayed 0-5 sec).

The O/C Shear-Pin contact can be used:

- For interlocking with other systems.
- For signaling.
- Used with delay for operating a reversing combination of upstream contactors when Shear-Pin is detected, thus, allowing clearing a Jam condition.

Control Terminals

Fault Contact **Terminals 13-14-15**
 Terminals: 13-N.O. 14-N.C. 15 – Common.

Voltage free 8A, 250VAC, 2000VA max. changes its position on fault. The contact is programmable to function as Trip or Trip – fail safe relay.

a. When Trip function is selected, the relay is energized upon fault. The contact returns to its original position after fault has been removed and starter was reset, or upon disconnection of Control Supply.

b. When Trip-fail safe function is selected, the relay is energized immediately when Control Supply is connected and de-energizes upon fault or Control Supply disconnection.

End of Acceleration Contact **Terminals 16-17-18**
 Terminals: 16-N.O. 17-N.C. 18 – Common.

Voltage free 8A, 250VAC, 2000VA max. changes its position at the end of acceleration, after an adjustable time delay (Contact Delay), 0 – 120 sec.

The contact returns to its original position, when Energy Saver is operated, on Soft Stop or Stop signals, on fault condition, or upon voltage outage.

The End of Acceleration contact can be used for:

- Closing a by-pass contactor.
- Activating a valve after compressor has reached full speed.
- Loading a conveyor after motor reached full speed.

External Fault **Terminal 19**
 Input from a N.O contact, connected between terminals 19 and 21. The starter will trip 2 sec. after contact closes.

WARNING

- Only potential free contacts may be connected to terminal 19.
- Do not connect any voltage to terminal 19. Any connection of voltage to this terminal may disrupt soft-starter operation, and cause starter or motor damage.

Notes:

- Wires connecting the External Fault contact to terminal 19 should not exceed 1 meter in length.
- External Fault can be used only when terminal 21 is connected to Neutral or Ground.
- Do not use External Fault while using Insulation Alarm option.

Tacho Feedback – Optional **Terminal 20**
 Provides linear acceleration and deceleration. Requires high quality Tacho generator on motor shaft, output voltage 0-10VDC, linear speed/voltage ratio. Consult factory before using Tacho feedback feature for further information.

Neutral **Terminal 21**
 When Neutral wire is available, connect Terminal 21 to Neutral (see pages 6, 8 & 10). Terminal 21 serves only as voltage reference.

Note: Starter’s power section incorporates an internal artificial neutral, which should only be used, when the system is not grounded and neutral connection is not available.

WARNING

- Only potential free contacts may be connected to terminal 21.
- Do not connect any voltage to terminal 21. Any connection of voltage to this terminal may disrupt soft-starter operation, and cause starter or motor damage.

Notes:

- Wires connecting between terminal 21 and terminal 19 should not exceed 1 meter in length.
- Do not use External Fault when terminal 21 is not connected to Neutral or Ground.

Terminal 21- Connections with various mains.

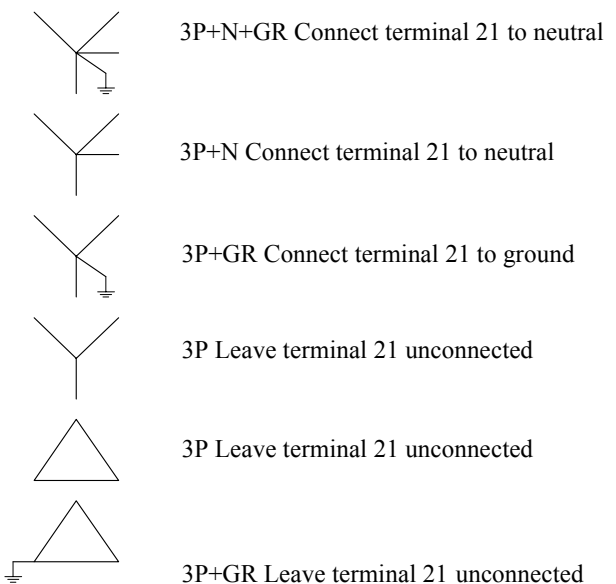

Control Terminals – Option Boards

Option # 3

RS-485 Communication **Terminals 23-24**
Terminals: 23 (-), 24 (+)

Standard RS485, Half Duplex with MODBUS Protocol, baud rate 1200, 2400, 4800, 9600 BPS. Twisted shielded pair should be used, connect shield to ground a PLC/Computer side. Terminals 4 & 5 must be wired to control supply for operation in communication mode (see Wiring Diagram – page 14 and Communication Instruction Manual).

Option # 4

Insulation Alarm **Terminals 25-26-27**
Terminals: 25- Common 26- N.O. 27 – N.C.

Voltage free 8A, 250VAC, 2000VA max. changes its position when motor insulation level decreases below Insulation Alarm level. The contact returns to its original position, after fault has been removed and starter reset, or upon Control Supply disconnection, or when insulation level increase above Alarm set-point for more than 60 sec.

Notes:

- Do not use External Fault while using Insulation Alarm option.
- Insulation test can be performed only when main voltage is not connected to the RVS-DN, namely an upstream isolation device must be opened.
For correct operation of Insulation test, it is important that the RVS-DN is properly grounded and that the control module is properly fastened to the power section.
- Option # 4 and option # 5 may not be applied together.

Option # 5

Analogue I/O (option # 5) **Terminals 28-32**

The Analogue card output incorporates two functions:

- Thermistor input
- Analogue output

Analogue P.C.B. layout:

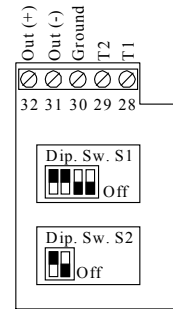

Thermistor input **Terminals 28-29**
Programmable as PTC or NTC type thermistor. Trip value is adjustable between 1-10K, preset delay of 2 Sec.

Ground Terminal **Terminal 30**
Connect thermistor and / or Analogue output shield to this ground terminal.

Analogue Output **Terminals 31, 32**
Terminal: 31 (-), 32(+)
Dip switches allow selection between: 0-10VDC
0-20mA
4-20mA

Analogue value is related to motor current and can be programmed to normal or inverted output. (Default = Normal) Maximum value (20mA or 10Vdc) is related to twice the RVS-DN rated current (2xFLC).

| Dip No. | 4-20 mA* | 0-20 mA | 0-10VDC |
|----------------|----------|---------|---------|
| Dip-Sw. S1 # 1 | On | On | Off |
| Dip-Sw. S1 # 2 | On | On | Off |
| Dip-Sw. S1 # 3 | Off | Off | On |
| Dip-Sw. S1 # 4 | Off | Off | On |
| Dip-Sw. S2 # 1 | On | Off | Off |
| Dip-Sw. S2 # 2 | No use | No use | No use |

* Default

Notes:

- It is important that the RVS-DN is properly grounded, and control module is tightly fastened to the power section.
- Option # 5 and option # 4 may not be applied together.
- Use twisted shielded cable for thermistor connection.

Control Wiring

Internal Jumper-see page 13

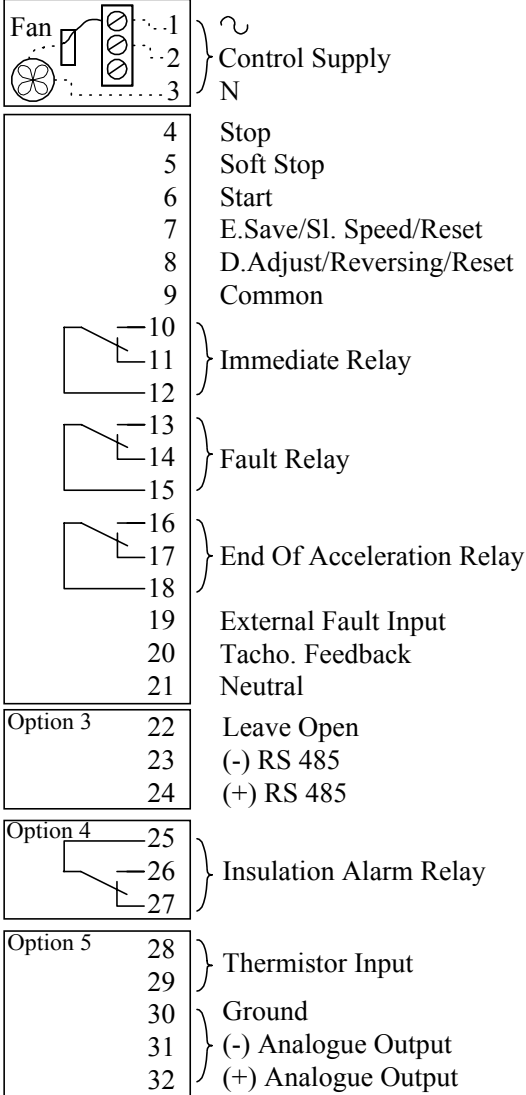

Fusing – Control Supply must be protected by a 6A fuse. It is recommended to use a separate fuse for the auxiliary circuits.

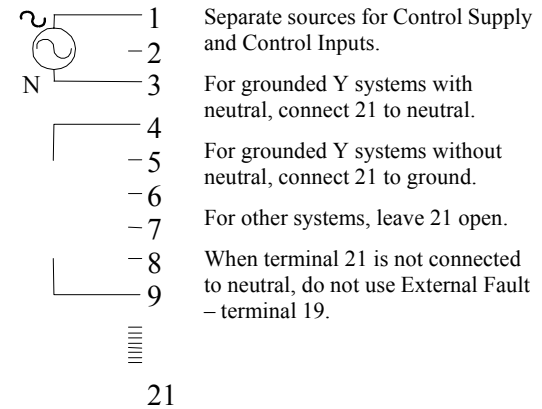
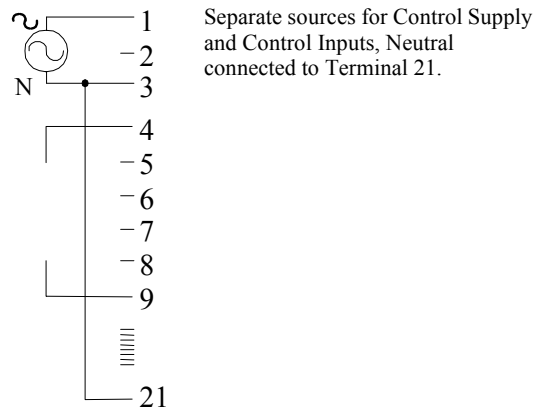
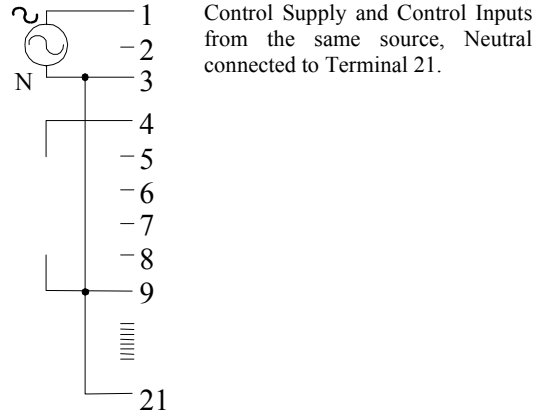

WARNING
Incorrect connection of terminal 19 and 21 may disrupt soft-starter operation and cause starter or motor damage.

Wiring Diagrams

1. Start, soft stop and stop buttons, single supply source for Control Supply and Control Inputs. If Soft Stop is not used, connect a jumper between terminals 4-5 connect emergency stop and /or soft stop between terminals 1-4.

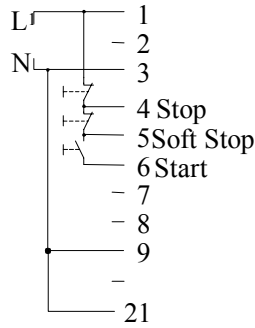

2. Start-Stop push buttons, Separate sources for Control Supply and Control Inputs. If Soft Stop is not used, connect a jumper between terminals 4-5.

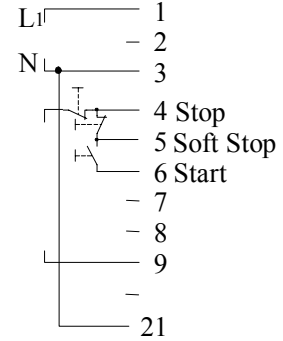

3. Motor will soft start when C closes and stops immediately when C opens.

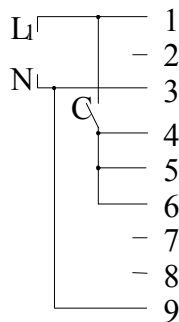

4. Motors will soft start when C closes and soft stop when C opens

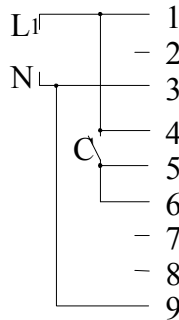

5. Motors will soft start and soft stop with C. C1 act as emergency stop.

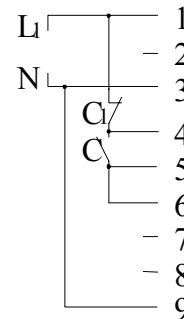

6. Close C to operate Energy Save, Slow speed or Reset – as selected.

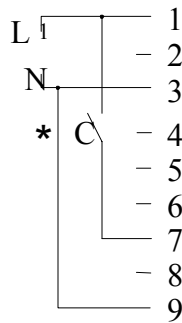

7. Close C to operate Dual Adjust. Slow Speed Reversing or Reset – as selected.

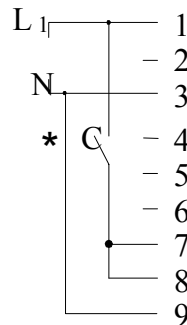

8. External Fault contact. The starter will trip 2 sec after C closes.

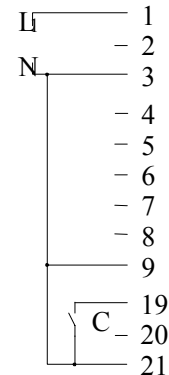

C must be of momentary type when used as Reset

For Slow speed reversing terminal 7 must be connected to Control Supply

Must Not be used when 21 is not connected to neutral/ground or when Insulation Test is used

- Notes:** 1. Terminal 21 may be connected to terminal 3 only if terminal 3 is at neutral or at ground potential.
2. Resetting is possible only after start signal is removed

Series contactor

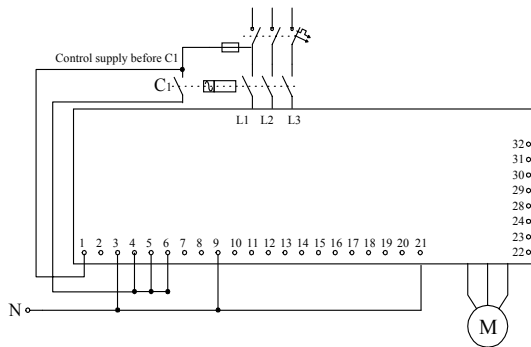

This system is mainly used when the RVS-DN is retrofitted into an existing system, to reduce modifications in existing installations.

Main power and Start signal are switched on upon closure of the series contactor. The starter will operate as long as the series contactor is closed.

Control supply obtained from main voltage must match starter's Control Supply voltage.

Notes:

1. It is recommended that terminals 1-3 be always connected to Control Supply.
2. In some applications, it is required to open the upstream contactor after soft stopping. The upstream contactor can be operated by the Immediate Contact that changes its position only at the end of soft stop.

It is therefore recommended to delay the opening of the upstream contactor for a few seconds after the completion of Soft stop process, when current reached zero, see Immediate/Shear-pin Contact delay – page 7.

- Ensure that auxiliary contact C_1 closes after the main contactor “the soft-starter provides a 500 mSec. delay for the start signal. If it closes before, Under Voltage, fault will occur. It is recommended to use a time delay timer to prevent possible faults.

By-pass contactor

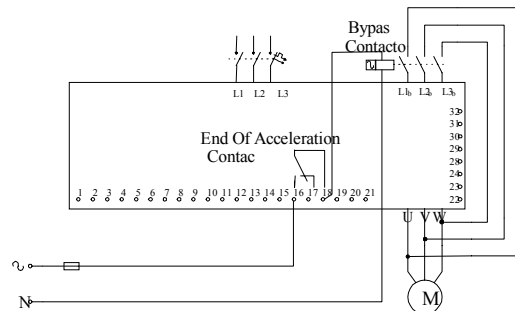

End of Acceleration contact is activated after an adjustable time delays “Run Contact Delay” – see page 29 at the end of start-up period, closing the by-pass contactor.

The contact will return to its original position when:

- Soft Stop or Stop signals are initiated
- Energy Saver signal is initiated
- Slow-Speed signal is initiated
- Fault condition occurs.

When the by-pass contactor closes, current to the motor will flow through the by-pass.

Note: When a by-pass contactor is used, it is recommended to order the starter with preparation for by-pass contactor, so that the RVS-DN current protections are operative also after the by-pass contactor closes.

When a Soft Stop signal is given, the End of Acceleration contact returns to its original position opening the by-pass contactor. Thereafter, the voltage will gradually ramp down to zero, soft stopping the motor.

Wiring Diagrams

Reversing with 2 series contactors

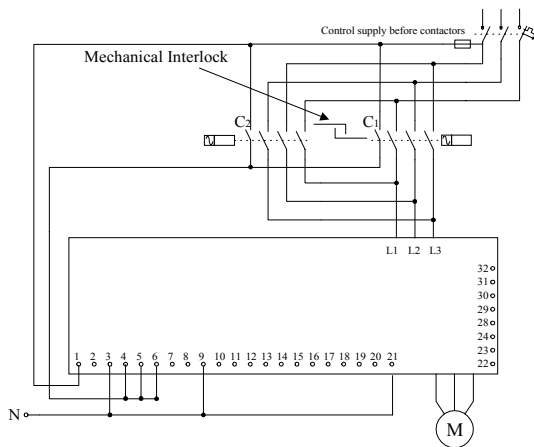

The start-stop control is by a N.O auxiliary contact in each of the two series contactors C₁ & C₂. Closure of either contactor will supply main power and a start signal to the RVS-DN.

Control voltage, obtained from main, must match the starter's Control Supply voltage.

Note:

1. It is recommended to employ a mechanical interlock between the Forward and Reverse Contactors.
2. It is required to delay the transfer between opening of one contactor and closing of second contactor.
3. Phase Sequence fault must be disabled to operate Reversing Contactors at the Line Input of the soft-starter.

Two Speed Motor

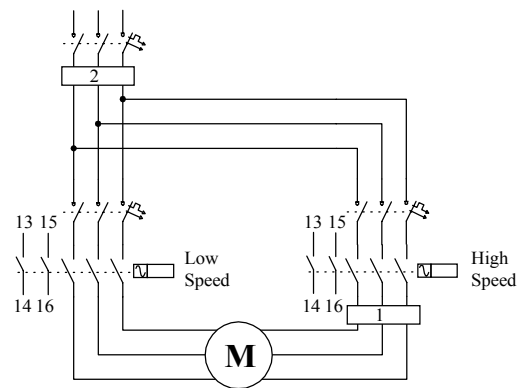

Used for Two Speed Motors:

* When soft start is required during transfer from low to high speed, the RVS-DN should be installed downstream to the high speed contactor (marked 1) and operated by its auxiliary contact (13-14).

* When soft start is required for both low and high speeds, the RVS-DN should be mounted before both contactors (marked 2) and operated by each of the downstream contactors (13-14 of each contactor).

Note: The RVS-DN should be sized for appropriate motor rating of either the low or the high speed.

If two different motor ratings and/or starting characteristics are required, for example, higher Initial Voltage and Current Limit for high speed, use the Dual Adjustment feature (see Dual Adjustment – page 21) which allows two different settings of:

- * Initial Voltage
- * Current Limit
- * Acceleration Time
- * Deceleration Time
- * Motor FLA.

An additional N.O. contact (15-16) on the high-speed contactor should act as the Dual Adjustment Switch. It should close simultaneously with 13-14 of the same contactor to start the RVS-DN and to switch to the Dual Adjustment settings.

Wiring Diagrams - Communication

Operation via communication link with Local / Remote selector switch

- * Remote: via Communication link
- * Local: Soft-start, soft stop by maintained contact

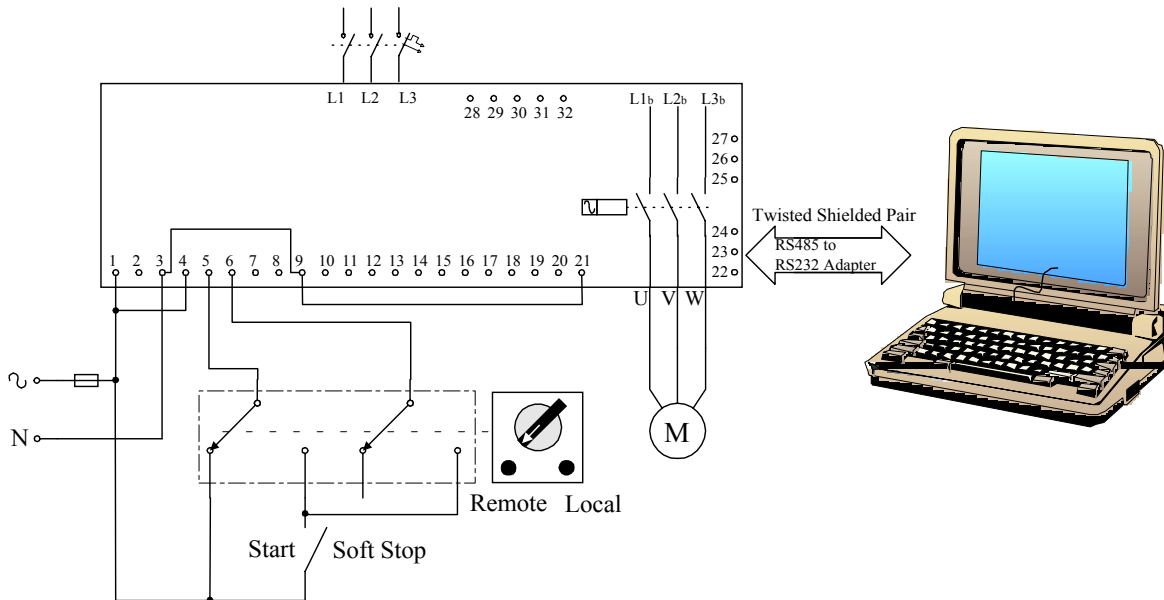

The communication enables remote parameter settings and reading. For start, stop, soft-stop, dual adjusts, etc terminals 4 and 5 must be wired as shown.

Soft-start and soft-stop

- Program the “Serial Link Number” in the communication page to a number between 1-247.
- Disconnect control supply, so the new information will be loaded on the next time you turn it on.
- Connect a communication line (twisted shielded pair) with its (+) to RVS-DN terminal 24 and (-) to terminal 23, connect the other end to your computer containing RS-485 communication port with MODBUS protocol.
- Connect other RVS-DN terminals as follows:
 1. Terminal 1, 3 and Control Supply.
 2. Terminal 4 to Control Supply phase.
 3. Terminal 9 to Neutral (or the Common for terminals 4,5,6).
 4. During operation via communication link, terminal 5 is connected through the “Local-Remote” selector switch to Control Supply and Start-Stop commands are controlled through the communication port.
During operation in Local mode, terminals 5 and 6 are connected to Control Supply through the Start/Stop toggle switch.
 5. Terminal 21 should be at ground potential.



WARNING

The host computer must be grounded when communicating with RVS-DN (unless using a Lap-Top Computer).

Wiring Diagrams - Communication

Operation via communication link with Local/Remote (selector switch)

- Remote: via Communication link
- Local: Soft-start, immediate-stop by maintaining contact.

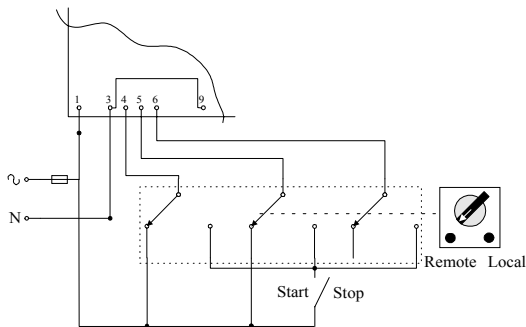

Soft-start and immediate stop

Same as the explanation for **Soft-start** and **soft stop**, except for # 4:

4. During operation via communication link, terminals 4 and 5 are connected through the Local / Remote selector switch to Control Supply and Start-Stop commands are controlled through the communication port.

During operation in Local mode, terminals 4, 5 and 6 are connected to Control Supply through the Start-Stop toggle switch.

Operation via communication link with Momentary contact (Push-Buttons) Soft-start, immediate stop, soft-stop.

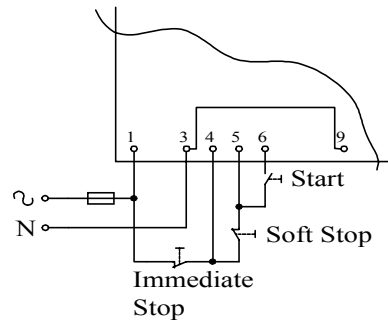

Soft-start, Soft-stop and immediate stop

Same as the explanation for **Soft-start** and **soft-stop**, except for # 2 and # 4:

2. Connect terminal 4 as described below.
4. During operation via communication link, terminals 4 and 5 are connected through the push buttons to Control Supply and Start-Stop commands are controlled through the communication port.

During normal operation mode, terminals 4 and 5 are connected to Control Supply through the Immediate-stop and soft-stop push buttons, soft-start command may be initiated by pressing the start push-button.

Notes: The communication (data retrieval and statistics) is active at all times!

When control signals (start, stop, etc.) are required, terminals 4 and 5 have to be wired in accordance with the appropriate wiring diagram:

1. Maintained soft-start and stop
2. Maintained soft-start with immediate stop.
3. Soft-start/stop with immediate stop via push-button control.

Wiring Diagrams – Diesel Generator

Starting from Diesel-Generator

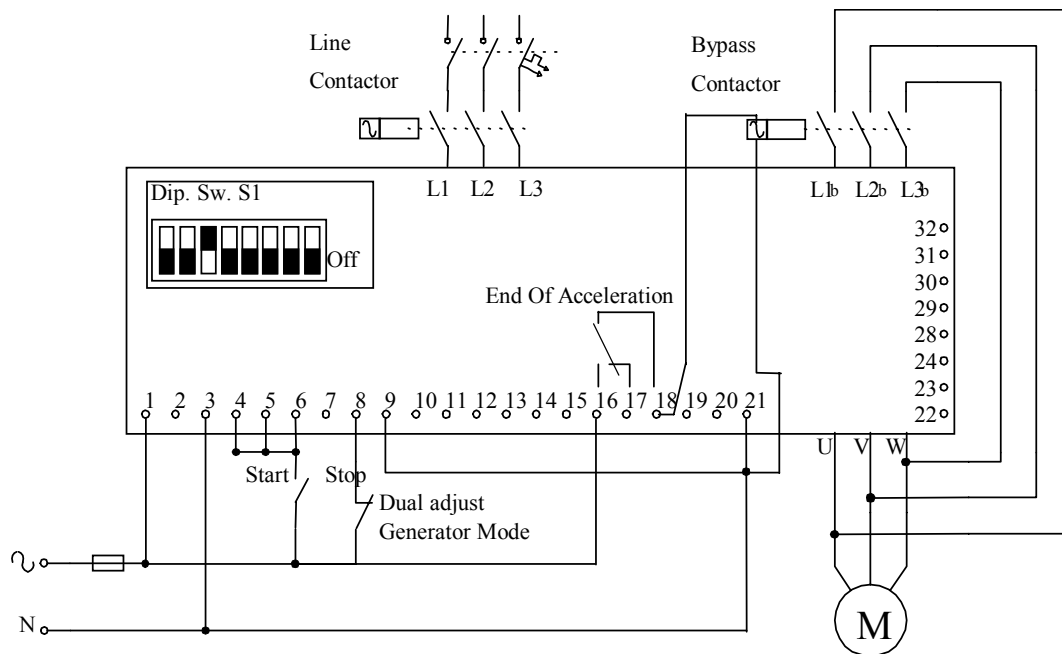

1. When starting from a Diesel-Gen., its voltage regulator (especially older type regulators) may be affected during the starting process, causing rapid voltage fluctuations (~350V to ~500V in 400V systems). In these rare cases, the voltage regulator must be upgraded – consult your Diesel-Gen. Supplier.
2. In most other cases where voltage, current or frequency is unstable – a special routine may be applied to overcome the starting difficulty. Use the procedure below:-
 - a. Set Dip. Switch # 3 to “On” (as shown above).
 - b. Insert a contact (or jumper) between Control Supply and terminal 8 (Dual Adjust. Terminal) and close contact to operate the Generator Mode. Dual Adjust LED will light when operating in Generator Mode.
 - c. Set Dual Adjust parameters to the values necessary for the application (e.g. faster acceleration, lower current limit, etc.).
3. When operating from Main and alternatively from Diesel Gen. Set normal starting characteristics for Main and suitable parameters for the Diesel Gen. in the Dual Adjustment setting. When starting from Main, the primary settings (suitable for main starting) will be operative. Upon starting from Generator, close contact between Control Supply and Terminal 8 to operate on Generator Mode.

Note: Ensure that Diesel Gen. size is suitable (Diesel Gen. KVA should be at least is 1.35 motor KVA, consult factory for all other cases).



WARNING

1. Motor can not run idle and must be loaded when operating in Generator Mode, otherwise vibration may occur during starting and stopping.
2. When using extended range, use maximum precaution to avoid motor or starter burnout.
3. Disconnect all other loads before starting for the first time to prevent damages due to voltage fluctuations.
4. Disconnect Power Factor Capacitors when operating with Diesel Gen.
5. Connect terminal 21 to terminals 3 and/or 9 only if these terminals are connected to neutral or at ground potential.
6. Only potential free contacts may be connected to terminal 21. Do not connect any voltage to terminal 21. Any connection of voltage to this terminal may disrupt soft-starter operation, and cause starter or motor damage.

Wiring Diagrams – Brake Motor & Insulation Test

Brake Motor

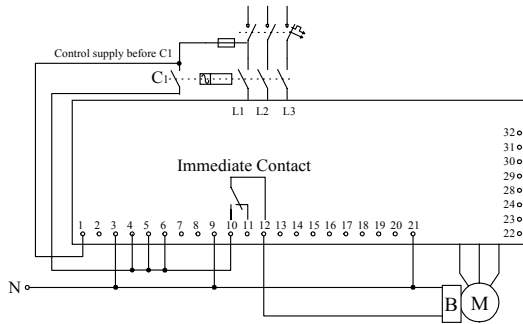

Upon starting, the “Immediate” contact is activated releasing the brake and allowing the voltage to ramp up (this contact will operate without a delay as long as “Immediate Relay ON delay” is set to 0 – see page 27). Upon stopping, the contact returns to its original position and the brake will close.

Note: Use an interposing relay when:

- a. Brake voltage is different from starter’s Control Input voltage.
- b. Brake current is greater than relay’s maximum Current (8A).

Caution: It is not recommended to use soft-starters in Vertical hoists applications.

Insulation Test Wiring

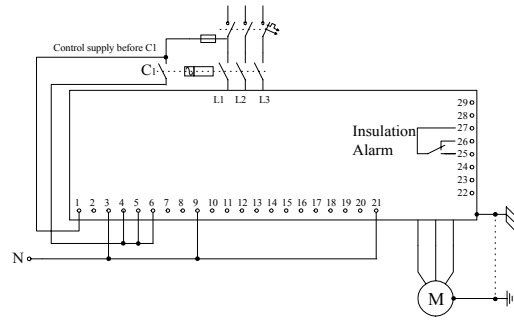

Few conditions must exist for the Insulation circuitry to operate, hence:

1. “On” and “Stop” LED’s must be ON.
2. The series contactor has to be “Open”.
3. Motor and starter must be properly grounded.
4. “External Fault” (terminal 19) can not be used.

Note: The Insulation circuitry begins operation after 120 seconds.

Internal Settings

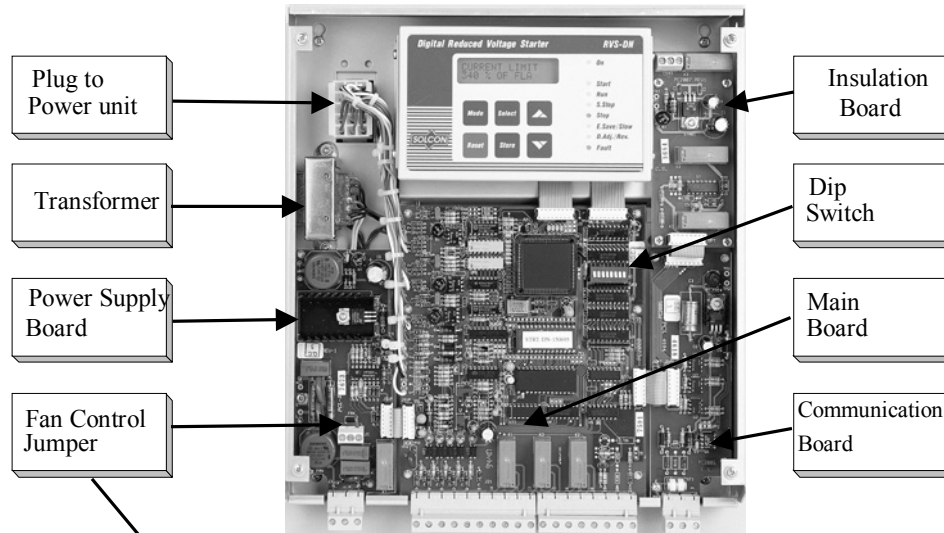

Fan Control

Starter's fan(s) can be controlled by in internal jumper. It is recommended to use continuous operation as default.

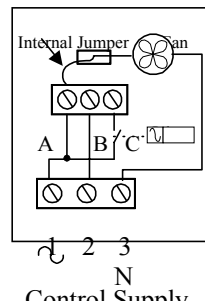

- **Continuous operation** (default connection) – The internal jumper is connected to terminal A. Fan(s) will operate continuously as long as Control Supply is connected.
- **External Control** - Connect the jumper to terminal B. Connect terminal 2 to Control Supply through an external contact. Fan(s) will operate when the external contact closes and stop when it opens.
- **Automatic operation** – Connect the jumper to terminal C. Fan(s) will operate automatically for a few minutes after start. The fan(s) will stop automatically a few minutes after stop signal.

WARNING

1. The starter is supplied with the internal jumper connected to terminal A, for continuous operation. If changed, it is the Customer's responsibility to operate the Fan(s).
2. Use only when by-pass contactor is utilized.

Built-in memory systems

The RVS-DN incorporates 3 memory systems:

EPROM A read-only, non-volatile memory, containing factory set parameters (default) that cannot be changed.

EEPROM A read/write, non-volatile memory, where field adjusted parameters, statistical and fault data are saved and stored.

RAM A read/write memory containing parameters loaded from the EEPROM which can be changed from the keypad. These parameters are stored only as long as Control Supply is connected.

Memory system operation

1. When Control Supply is switched on, the RAM is automatically loaded from the EEPROM and parameters are displayed on the LCD.
2. Parameters can now be modified from the keypad (if starter is in one of the operating modes and software lock is open – Dip Sw. 8 open).
3. Start Parameters can be modified during starting process and will immediately affect the operation. For example, if Current Limit is set too low and motor does not accelerate to full speed, increasing Current Limit setting will immediately affect starting process. This enables selection of the optimal starting characteristics. After completion of the adjustments, parameters should be stored in the EEPROM. Storing new parameters is possible at the end of each Mode Page by pressing Store key after "Store Enable" is displayed on the LCD.

Internal Settings

Inside Delta Motor Connection Mode

Allows connection of the RVS-DN inside the Delta. Current is reduced by 1.73 ($\sqrt{3}$), namely for an 800A motor the standard selection will be an 820A soft-starter. "In the Delta", the calculation will be $800 / 1.73 = 460A$, hence, for a 800A motor, a 460A "Inside Delta" starter is selected. Programming via first window in "Main Parameters". Selectable options are: either "Line" or "Inside Delta". See Appendix for "Inside Delta" details and motor connection diagram.

Dip Switch settings

The Dip Switch, containing eight separate switches, is located under the front cover of Control Module (in sizes B-F) and under the Display unit (in size A).

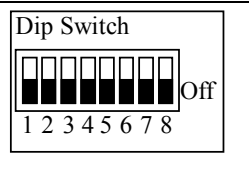

When necessary, carefully open the front panel and set the switches as required.

Note: All switches are factory set in OFF position.

| No | Switch Function | Switch Off | Switch On |
|-----|---|------------|-----------|
| 1 | Display Format | Minimized | Maximized |
| 2 | Tacho feedback | Disabled | Enabled |
| 3 | Main / Generator | Main | Generator |
| 4 | Must be Off | | |
| 5-6 | LCD-language selection | See table | |
| 7 | Special settings - keep in Off position | Disabled | Enabled |
| 8 | Software lock | Open | Locked |

Switch # 1 – Display Modes

For operation convenience, there are two display modes,

Maximized – Display of all possible parameters.

Minimized – Display of pre-selected parameters.

Setting Dip Sw. # 1 to Off will minimize the LCD displays.

Maximized mode

Switch 1 – On

Display only
Main parameters
Start parameters
Stop parameters
Dual adjustment
Energy save parameters
Slow speed parameters
Fault parameters
I/O programming
Communication parameters
Statistical data

Minimized mode

Switch 1 – Off

Display only
Main parameters
Start parameters
Stop parameters
Statistical data

Switch # 2 – Tacho feedback (0-10VDC)

Set Dip Sw. # 2 to On, when using Tacho feedback.

Note: To operate tacho feedback – consult factory for specific settings for each application.

Switch # 3 – Main / Generator control

When starting from a diesel – generator supply, starting process can sometimes terminate due to instability of the supply system.

Set Dip Sw. # 3 to On, special starting characteristics, suitable for Diesel Generator supply – with unstable voltage & frequency, becomes operative.

Closure of Dual Adjustment contact (terminal 8) operates the special starting characteristics.

When operating from mains and alternatively from diesel generator, set normal starting characteristics for mains and suitable parameters for the Diesel Generator (for example faster acceleration, lower current limiting, etc.) on Dual Adjustment setting.

WARNING

When operating in Generator Mode, motor must be loaded, otherwise, vibration may occur during starting and stopping.

Switches # 5, 6 – Language Selection

| Language | Switch 5 | Switch 6 |
|----------|----------|----------|
| English | Off | Off |
| French | Off | On |
| German | On | Off |
| Spanish | On | On |



Switch # 7 – Special settings – consult factory

WARNING

When using extended Soft-Starter range, apply maximum precautions to avoid motor or starter damage.

Switch # 8 – Software Lock

The software lock prevents undesired parameter modification.

When locked, upon pressing Store,  or  keys, the LCD displays "Unauthorized Access".

Start & Stop Parameters

Pump Control – Start Curves

Induction motors produce peak torque of up to 3 times the rated torque towards the end of starting process. In some pump applications, this peak may cause high pressure in the pipes.

The RVS-DN incorporates 4 different starting curves:

Start Curve 0 – Standard curve (Default). The most stable and suitable curve for the motor, preventing prolonged starting and motor overheating.

Start Curves 1, 2, 3 – During acceleration, before reaching peak torque, the Pump Control Program automatically controls the voltage ramp-up, reducing peak torque.

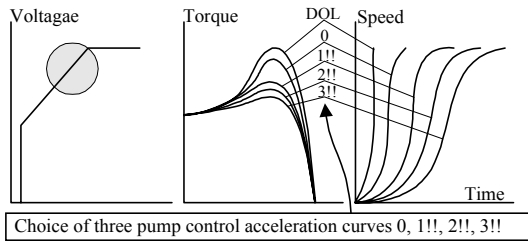

Start Curve 4 (Torque) – Torque Controlled acceleration, provides a smooth time controlled torque ramp for the motor and the pump.

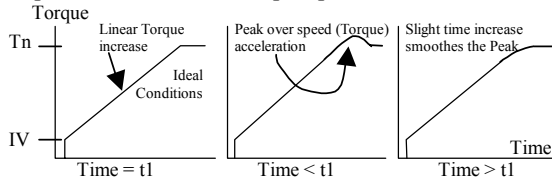

Note: Always starts with Start Curve 0. If towards end of acceleration, peak torque is too high (pressure is too high), proceed to Curve 1, 2, 3 or 4 if necessary.

Tacho Feedback, 0-10VDC (Optional)

Provides linear acceleration and deceleration curves according to rpm feedback. 12 tacho gain levels can be selected for closed loop control starting and stopping.

Note: Consult factory for additional information.

Pulse Start

Intended to start high friction loads, requiring high starting torque for a short time.

A pulse of approx. 80% U_n without Current Limit is initiated to break the load frees. Pulse duration is adjustable, 0.1 – 1 sec.

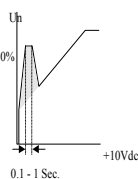
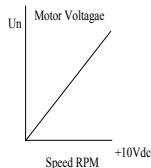

After this pulse, the voltage is ramped down to Initial Voltage setting, before ramping up again to full voltage according to Start Parameters settings.

Initial Voltage

Determines motor's initial starting torque (the torque is directly proportional to the square of the voltage).

Range: 10-50% U_n (consult factory for extended range). This adjustment also determines the inrush current and mechanical shock. A setting that is too high may cause high initial mechanical shock and high inrush current (even if Current Limit is set low, as the **Initial Voltage setting overrides Current Limit setting**).

A setting that is too low may result in prolonged time until motor begins to turn. In general, this setting should ensure that the motor begins turning immediately after start signal.

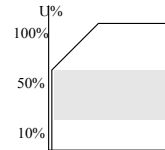

Current Ramp (Initial Current)

Determines initial Ramp-Up starting Current. When desired, increase Initial Voltage to Max. (50% or 80% respectively). The LCD displays "Initial Current" and the starter will linearly Ramp Up the current following the desired acceleration time. Range: 100-400%

Current limit

Determines motor's highest current during starting. Range 100-400% of FLA setting (consult factory for extended range). A too high setting will cause greater current drawn from main and faster acceleration.

A setting that is too low may prevent motor from completing acceleration process and reaching full speed. In general, this setting should be set to a high enough value in order to prevent stalling.

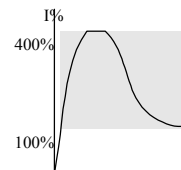

Note: Current limit is not operating during Run and Soft stop.

Acceleration Time

Determines motor's voltage ramp-up time, from initial to full voltage. Range 1-30 sec. (consult factory for extended range). It is recommended to set Acceleration Time to the minimum acceptable value (approx. 5 sec).

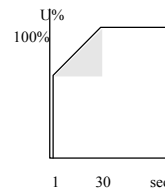

Notes:

1. Since Current Limit overrides Acceleration Time, when Current Limit is set low, starting time will be longer than the preset acceleration time.
2. When motor reaches full speed before voltage reaches nominal, Acceleration Time setting is overridden, causing voltage to quickly ramp-up to nominal.
3. Using starting curves 1, 2, 3 prevents quick ramp up.

Start & Stop Parameters

Maximum Start Time

The maximum allowable starts time, from start signal to end of acceleration. If voltage does not reach full voltage during this time (for example, because of low Current Limit setting), the starter will trip the motor. LCD displays “Long Start Time” message. Range: 1-30 sec (consult factory for extended range).

Contact Delay

Time delay for End of Acceleration Contact, after completion of starting process. Range: 0-120 sec.

Pump Control – Stop curve

Intended to prevent Water Hammer during stopping. In pump applications, load torque decreases in square relation to the speed, thus, reducing the voltage will reduce torque and motor will smoothly decelerate to a stop.

The following **Stop curves** can be selected:

Stop curves 0 – Standard Default curve – voltage is linearly reduced from nominal to zero.

Stop curves 1, 2, 3 –

In some pump applications, when pumping to a higher level, a considerable part of the torque is constant and does not decrease with speed. It may happen that during Soft Stop, when voltage is decreasing, motor torque quickly falls below load torque and motor will abruptly stall instead of smoothly decreasing speed to zero.

curves 1, 2, 3 designed to prevent stall condition

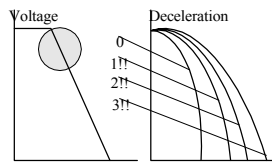

Stop Curve 4 (Torque) –

Provides Linear Controlled torque deceleration ramp, from T_a (Actual Torque), thus, eliminating stall conditions.

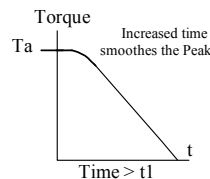

Note: Always use Stop Curve 0. If motor stalls quickly instead of slowly decreasing its speed, select Stop Curve 1, 2, 3 or 4 if necessary.

Deceleration Time – Soft Stop

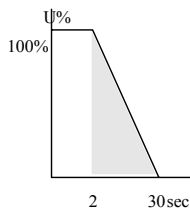

Used for controlled deceleration of high friction loads. Determines motor’s voltage ramp down time. Range: 1-30 sec. (consult factory for extended range).

Note: When the starter operates with a by-pass contactor, Soft Stop initiation opens the End Of Acceleration contact, tripping open the by-pass contactor. Load will then be transferred to the RVS-DN and voltage begins ramping down.

Final Torque

Determines torque towards end of Soft Stop. If current is still flowing after speed is softly reduced to zero, increase Final Torque setting.

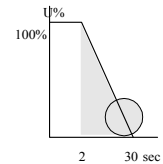

Dual Adjustment

A secondary set of parameters, used for varying loads, two speed motors, etc. Connecting Control Supply to Terminal 8 makes transfer to Dual Adjustment settings.

- IV - Initial Voltage 10-50% of Un.
- CL - Current Limit 100-400% of motor’s FLA
- AT - Acceleration Time 1-30 sec.
- DT - Deceleration Time 1-30 sec.
- FLA- Motor Full Load Ampere.

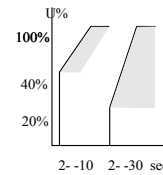

Note: Consult factory for extended range.

Energy Save

Activated when motor is lightly loaded for extended periods of time. Supply voltage the motor decreases (lowering the rotating magnetic field intensity), thus, reducing the reactive current and copper/iron losses.

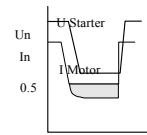

Note: When using Energy Save system, harmonics should be taken into consideration. At maximum Energy Save settings, the 5th harmonic may exceed 30% of the RMS current value.

ATTENTION

To meet CE standards while in Energy Save mode, the user may be required to employ additional mitigation methods.

Slow Speed Torque

Determines the torque while motor is operating at 1/6 of nominal speed. Range: 1-10.

Maximum Slow Speed Time

Determines the maximum allowable operation time at slow speed. Range: 1-30 sec. (consult factory for extended range).

WARNING

Operating current while motor is running at 1/6 speed is much higher than nominal current and motor ventilation is much weaker. Special precaution must be taken to prevent overheating when running the motor at slow speed for long periods of time.

Motor & Starter Protection

Motor Insulation (option)

Operational when motor is not running (the motor must be galvanically isolated). Two distinct level can be set for Alarm and Trip functions.

- Alarm level, Range: 0.2 – 5 MΩ
- Trip level, Range : 0.2 – 5 MΩ

When insulation decreases below Alarm Level set point for more than 120 sec., the LCD displays ALARM:

INSULATION LEVEL and shows the value in MΩ.

The Fault LED flashes and the Insulation Alarm Relay is activated.

Alarm signal will disappear automatically 60 seconds after insulation level returns to normal. Trip does not reset automatically.

When insulation decreases below Trip Level set point, the LCD displays TRIP: INSULATION LEVEL and shows the value in Mohm. The fault LED illuminates and Fault Relay is activated.

Motor Thermistor (option – Analogue Card)

Measures motor's thermistor resistance and trips the starter when level decreases below set level. Only one of the optional cards can be fitted in one starter, Analogue card or Insulation card.

Thermistor Type: Selectable PTC or NTC.

Trip Level, range: 1 – 10 KΩ

Delay: Factory preset time delay of 2 sec.

Too Many Starts

Combines three parameters:

- **Number of Starts**
Determines maximum allowable number of starts.
Range: Off, 1-10 starts.
- **Start Period**
Time period during which Number of Starts is being counted. Range: 1-60 min.
- **Start inhibit**
Determines time period during which starting is disabled after "Too many starts" trip.
Range: 1-60 min

Note: Motor can not be started before "Start Inhibit Time" has elapsed. Trying to start the motor during this time delay will result in LCD displaying "Wait Before Rst: ___ MIN.

Long Start Time – (Stall Protection)

Trips the starter if motor does not reach full speed during "Maximum Start Time".

Range: 1-30 sec. (consult factory for extended range).

Over Current Shear-pin

Becomes operational when starter is energized and has two Trip functions:

- Trips the starter when current exceeds 850% of starter's FLC setting in 1 cycle or less.
- During run (after RUN LED is lit) – Trips the starter when current exceeds set level and time delay.

Range: 200 - 850% of motor FLA setting

Delay: 0 – 5 sec. (0=up to 200 mSec)

Note: The O/C Shear-Pin is not intended to replace the fast acting fuses, required to protect the thyristors (see fuse table in the appendix).

Overload (O/L)

Inverse time electronic overload becomes operational when RUN LED is lit.

The O/L circuitry incorporates a Thermal Memory Register calculating heating minus dissipation of the motor. The starter trips when the register fills up. The thermal register resets itself 15 minutes after motor stops.

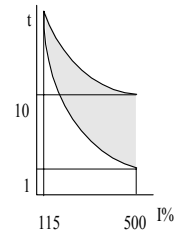

Adjustable between 75-150% of motor's FLA and factory set at 115%.

Tripping time at 500% FLA is adjustable between 1-10 sec. Allowing trip curve selection.

ATTENTION

Overload protection is not operative during soft-start or soft stop.

Under Current

Operational when motor is running. Trips the starter when motor current drops below set Under Current Trip (UCT) for a time longer than Under Current Delay (UCD).

Under Current Trip, Range: 0=Off, 20-90% of FLA
Under Current Delay. Range: 1-40 sec.

Under Voltage

Becomes operational only after start signal. Trips the starter when main voltage drops below the set Under Voltage Trip (UVT) for a time longer than Under Voltage Delay (UVD).

Under Voltage Trip, Range: 120-600V (phase to phase)
Under Voltage delay, range 1-10 sec.

Note:

When voltage drops to zero (full voltage outage) the starter will trip immediately, overriding the delay.

Motor & Starter Protection

Over Voltage

Becomes operational only after start signal. Trips the starter when main voltage increases above the set Over Voltage Trip (OVT) Level for an adjustable period of time longer than Over Voltage Delay (OVD).
Range: 150 – 750V (phase to phase)
Over Voltage Delay, Range: 1-10 sec.

Phase loss (and Under / Over Frequency)

Becomes operational when starter is energized and protects motor from single phasing. Trips the starter when 1 or 2 phases are missing for more than 1 sec.

Starter will also trip when frequency is less than 40 or greater than 65Hz.

Note: Phase loss might not be detected in lightly loaded motors.

Phase Sequence

Becomes operational when starter is energized, provided this protection has been activated (Fault Enable – Phase Sequence Protection, see Fault Parameters). Trips the starter when phase sequence is wrong.

Long Slow-Speed Time

Trips the starter if motor operates at slow speed for a time longer than “Maximum Slow Speed Time”
Range: 1-30 sec. (consult factory for extended range).

Note: Operate motor at slow speed for the minimum possible time to prevent overheating. When motor operates at slow speed, it draws higher than nominal current (depending on Slow-Speed Torque adjustment) thus, motor and starter may overheat.

Wrong Connections

Become operational after start signal. Trips if motor is not properly connected to starter’s Load terminals, or when:
Internal disconnection in the motor winding is detected.

Shorted SCR

Trips the starter in case one or more SCRs have been shorted.

Heatsink Over Temperature

Thermal sensors are mounted on the heatsink and trip the starter when temperature rises above 85°C.

WARNING

The over temperature protection is designed to operate under normal conditions e.g. in the event of extended low overload, insufficient ventilation – fan stoppage or air flow blockage.
Incorrect starter selection or operation frequents starting at max. conditions, or repeated starting under fault conditions can cause SCRs to overheat and fail before the heatsink reaches 85°C to trip the thermal sensors.

External Fault

Becomes operational when starter is energized, trips the starter when an External Contact closes for more than 2 sec.

WARNING

Do not use External Fault when terminal 21 is not connected to ground.

Fault and Reset

When any of the above protection (except Insulation Alarm) operates, the starter locks in a fault condition, disabling thyristors firing. Fault LED lights up, fault description is displayed on the LCD and Fault Relay operates.

- For local resetting, after fault has been removed, press Reset key.
- Remote resetting can be done through terminals 7 or 8 (see I/O Programming).

When Fault occurs, followed by a voltage outage, fault condition is latched and reappears upon voltage restoration.

Note:

Resetting is not possible as long as Start signal exists.

Auto Reset

Under-voltage and Phase-loss, faults can be set to Auto-Reset (see Fault Parameters). The starter will reset itself 60 sec. after voltage was fully restored provided no start signal exists.

Note:

Auto- Resetting is not possible as long as Start signal exists.

Front Panel

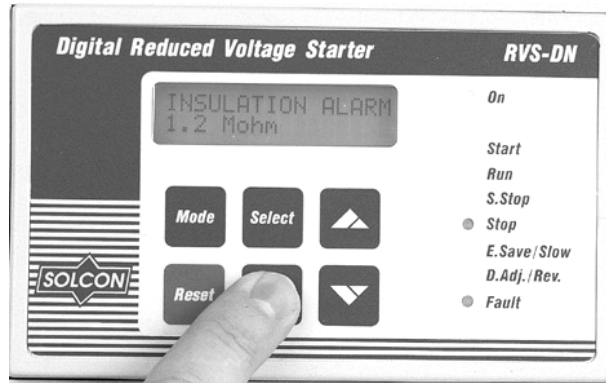

LED's Arrangement

On

Lights up when Control Supply voltage is connected to the starter.

Start

Lights up during start process, indicating that motor supply voltage is ramping up.

Run

Lights up after completion of starting process, indicating that motor is receiving full voltage. Flashes during slow speed operation.

S. Stop

Lights up during Soft Stop process, indicating that motor supply voltage is ramping down.

Stop

Lights up when motor is stopped.

E. Save / Slow

Lights up when "Energy Save" is in operation. Flashes when motor is running at Slow Speed.

D. Adj. / Rev

Lights up when Dual Adjustment is in operation. Flashes when motor is running in the Reverse direction at slow speed.

Fault

Lights up upon operation of any of the built-in protection. Flashes when Insulation Alarm (optional) relay is activated

Keypad

Provides selection of the following modes:
(When Dip Switch 1 is in "On", gray zone shows list of maximized parameters).

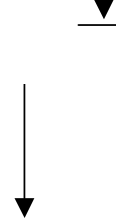
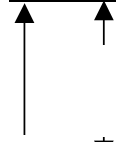

- Display Only
- Main Parameters
- Start Parameters
- Stop Parameters
- Statistical Data
- Dual-Adjustment Parameters
- Energy Saver and Slow Speed Parameters
- Fault Parameters
- I/O Programming Parameters
- Communication Parameters



To select function within each mode.



To increase adjusted parameters. Press momentarily or continuously.



To decrease adjusted parameters.



To save modified parameters.



To reset the starter after fault has been removed, canceling the displayed fault and allows restarting.

Note: Pressing Mode or Select continuously increases parameters changing speed.

Front Panel

LCD Arrangement



Two lines of 16 alphanumeric characters, displaying: System Parameters, Starter Settings, Motor Current, Insulation and Fault Identification.

Four selectable languages – English, French, German and Spanish (see Dip Switch setting – page 19).

CURRENT LIMIT
390%

- Upper line displays functions.
- Lower line displays setting and measured values.

Parameter Review and modification

1. Press mode key several times until you reach the required **Mode** page.
2. Press **Select** to review parameters of this Mode.
3. When reaching the required parameter, modifying its values with  or  keys.
4. To store the new parameters, press **Select** until “Store Enable” appears and then press **Store** key

Note: Pressing **Mode** or **Select** keys continuously increase parameter change speed.

Mode pages

Upon initiation of the starter, the LCD displays motor’s operating current.

% OF MOTOR FLA
98 %

When Dip Sw.#1 is set to On (see Display Options – page 19), by pressing the Mode key all **Mode** pages can be reviewed.

When Dip Sw. # 1 is set to Off, the following Mode pages marked ** will not appear.

MAIN PARAMETERS

START PARAMETERS

STOP PARAMETERS

** **DUAL ADJUSTMENT
PARAMETERS**

** **EN. SAVE & SL. SPD
PARAMETERS**

**FAULT
PARAMETERS**

** **I/O PROGRAMMING
PARAMETERS**

** **COMM.
PARAMETERS**

STATISTICAL DATA

Display Mode

In this mode, parameters cannot be adjusted

% OF MOTOR FLA

Displays operating current as a percentage of motor FLA.

Note: Starter's Default Display, after pressing Mode or Select, a time delay is initiated. Following the delay, the LCD defaults back to display "% OF MOTOR FLA".

Press Select – When Insulation card is incorporated

MOTOR INSULATION
52.8 Mohm

Displays motors winding insulation level

Press Select – When Analogue card is incorporated

THERMISTOR RES.
3.1 Kohm

Displays motor thermistor's resistance

When option cards are not incorporated, the LCD displays

OPTION CARD
Not installed

Press Select

ANALOGUE OUTPUT
Normal

Normal- Analogue output increases when current increases.

Inverted- Analogue output decreases when current increases.

Range: Normal, Inverted.

This concludes the DISPLAY Mode.

Pressing **Select** key at this point returns to the first display.

Obtaining "Default Parameters"

- Press **Mode** and  keys simultaneously, the LCD will display "Store Enable Default Parameters".
- Press **Store** + **Mode** keys simultaneously.

CAUTION

Obtaining Default Parameters erases all previously modified settings and requires the operator to program FLC and FLA values again.

Parameter Settings

Press Mode

To advance to:

MAIN PARAMETERS

Press Select

Press ▲ ▼ keys to set Starter's connection type.
(see Appendix for: Inside Delta description).

CONNECTION TYPE
LINE / INSIDE DELTA

Press Select

Press ▲ ▼ keys to set Starter's FLC.
(see RVS-DN ratings – Page 3).

STARTER FLC
105 AMP

Press Select

Press ▲ ▼ keys to set motor's FLA
Range: 50-100% of "STARTER FLC"

MOTOR FLA
105 AMP

Press Select

Press ▲ ▼ keys to set Under Current Trip.
Range: 0 = OFF, 20-90% of FLA

UNDERCURREN. TRIP
0% OF FLA

Press Select

Press ▲ ▼ keys to set under Current Trip Delay.
Range: 1-40 sec.

UNDERCURREN. DELAY
10 SEC.

Press Select

Press ▲ ▼ keys to set Over Current Shear-pin.
Range: 200 – 850% of FLA

O/C – SHEAR PIN
850% OF FLA

Press Select

Press ▲ ▼ keys to set O/C Shear-pin Delay.
Range: 0.5-5 sec.

O/C DELAY
1.5 SEC.

Press Select

Press ▲ ▼ keys to set Overload Trip Current.
Range: 75-150% of FLA

OVERLOAD TRIP
115% OF FLA

Press Select

Press ▲ ▼ keys to set Overload Delay
at 500% of motor FLA
Range: 1-10 sec.

OVERLOAD DELAY
4 SEC – AT 5 FLA

Press Select

Press ▲ ▼ keys to set Under Voltage Trip.
Range: 120-600V

UNDERVOLT. TRIP
300 VOLT

Press Select

Press ▲ ▼ keys to set Under Voltage Trip Delay
Range: 1-10 sec.

UNDERVOLT. DELAY
5 SEC.

Press Select

Press ▲ ▼ keys to set Over Voltage Trip.
Range: 150-750V (can not be set below Under
Voltage).

OVERVOLT. TRIP
480 VOLT.

Press Select

Press ▲ ▼ keys to set Over Voltage Trip Delay.
Range: 1 – 10 sec.

OVERVOLT. DELAY
2 SEC.

Press Select

To store selected parameters, press **Store** key.

STORE ENABLE
MAIN PARAMETERS

Note: Storing selected parameters is possible
only when Stop or Run LED are lit.
Storing cannot be done when Start, Soft
Stop, Slow Speed, Energy Save, or Fault
LED are lit.

When parameters have been correctly stored, the LCD
will read:

DATA SAVED OK

This concludes MAIN PARAMETER settings.

Pressing **Select** key after "Data Saved OK" returns to
the first display in this mode.

Note: In case of a failure in parameter storing,
the LCD displays:

STORAGE ERROR

Press **Select** button again until "Store Enable Main
Parameters" returns. Then press **Store** key until "Data
Saved OK" appears.

Parameter Settings

Press Mode

To Advance to:

START PARAMETERS

Press Select

SOFT START CURVE
0 (STANDARD)

Then press ▲ ▼ keys to set Soft Start Curve:

0 (Standard) = Standard Curve

1!! = Pump Control Curve # 1

2!! = Pump Control Curve # 2

3!! = Pump Control Curve # 3

4 (Torque) = Torque Control Pump Curve # 4

When setting Dip sw. # 2 On for Tacho Mode

Press ▲, following Curve #4 message changes to:

START TACHO. GAIN
0 (MIN. GAIN)

Then press ▲ ▼ keys to set Tacho gain:

0 = Minimum gain tacho, control

1!! = Second level tacho gain

2!! = Third level tacho gain

3!! = Fourth level tacho gain

4!! = Fifth level tacho gain

5!! = Sixth level tacho gain

Note: Tacho Feedback is operational in its basic form. Additional curves except for the basic linear curve are optional. Consult factory for correct tacho selection and mechanical installation.

Press Select,

Press ▲ ▼ keys to set Pulse Start Time.

Range: 0-1 sec. (Pulse level at 80% Un)

PULSE TIME
0 SEC.

Press Select,

Press ▲ ▼ keys to set Initial Voltage.

Range: 10-50% of Un.

INITIAL VOLTAGE
30%

When Up Arrow key is pressed at 50% Initial Voltage, the display will change to the current curve and show:

INITIAL CURRENT
100%

At this point, the choice of current will determine the Initial Current at the beginning of the starting curve.
Range: 100-400% of Motor FLA

Press Select,

Press ▲ ▼ keys to set Current Limit

Range: 100-400% of motor FLA.

CURRENT LIMIT
400% OF FLA

Press Select

Press ▲ ▼ keys to set Acceleration Time

Range: 1-30 sec.

ACC. TIME
10 SEC.

Press Select

Press ▲ ▼ keys to set Maximum Start Time

Range: 1-30 sec.

MAX. START TIME
30 SEC.

Press Select

Press ▲ ▼ keys to set Number of Starts permitted (During STARTS PERIOD below). Range: 1-10, Off.

NUMBER OF STARTS
10

Press Select

Press ▲ ▼ keys to set Number of Starts Time Period

Range: 1-60 min.

STARTS PERIOD
30 MIN.

Press Select

Press ▲ ▼ keys to set Start Inhibit Period

Range: 1-60 min.

STARTS INHIBIT
15 MIN.

Press Select

Press ▲ ▼ keys to set Time Delay for End of Acceleration Contact.

Range: 0-120 sec.

RUN CONTACT DEL.
5 SEC.

Press Select

To store selected parameters, press **Store** key

STORE ENABLE
START PARAMETERS

When parameters have been correctly stored, the LCD reads:

DATA SAVED O.K.

This concludes START PARAMETERS setting.

Parameter Settings

Press Mode

To advance to

STOP PARAMATERS

Press Select

Then press ▲ ▼ keys to set Soft Stop Curve

0 = Standard Curve

1!! = Pump Control Curve # 1

2!! = Pump Control Curve # 2

3!! = Pump Control Curve # 3

4 = Pump Control Curve 4 (Torque Control)

SOFT STOP CURVE
0 (STANDARD)

When setting Dip sw # 2 On for Tacho Mode,

Press ▲ curve message changes to:

STOP TACHO GAIN
0 (MIN. GAIN)

Then press ▲ ▼ keys to set Tacho gain:

0 = Minimum gain tacho, control

1!! = Second level tacho gain

2!! = Third level tacho gain

3!! = Fourth level tacho gain

4!! = Firth level tacho gain

5!! = Sixth level tacho gain

Note: Tacho Feedback is operational in its basic form. Additional curves except for the basic linear curve are optional. Consult factory for correct tacho selection and mechanical installation.

Press Select

Then press ▲ ▼ keys to set Deceleration Time.
Range: 1-30 sec.

DEC. TIME
10 SEC.

Press Select

Then press ▲ ▼ keys to set Final Torque during Soft Stop.

Range: 0 – 10 (0 = min., 10 = max.)

FINAL TORQUE
0 (MIN)

Press Select

To store selected parameters, press **Store** key

STORE ENABLE
STOP PARAMETERS

When parameters have been correctly stored the LCD displays:

DATA SAVED OK

This concludes STOP PARAMETERS setting.

Press Mode

To advance to (only when Dip Sw. # 1 is set to ON):

DUAL ADJUSTMENT
PARAMETERS

When selecting “Generator Mode” (Dip sw # 3 is On) the following display appears instead of the above.

D. ADJ: GENERATOR
PARAMETERS

Press Select

Then press ▲ ▼ keys to set DA: Initial Voltage.
Range: 10-50% of Un.

DA: INIT. VOLT.
30%

Press Select

Then press ▲ ▼ keys to set DA: Current Limit.
Range: 100-400% of motor’s FLA.

DA: CUR. LIMIT
400% OF FLA

Press Select

Then press ▲ ▼ keys to set DA: Acceleration Time.
Range: 1-30 sec.

DA: ACC. TIME
10 SEC.

Press Select

Then press ▲ ▼ keys to set DA: Deceleration Time.
Range: 1-30 sec.

DA: DEC. TIME
10 SEC.

Press Select

Then press ▲ ▼ keys to set DA: Motor FLA
Range: 50-100% of “STARTER FLC”

DA: MOTOR FLA
105 AMP.

Press Select

To store selected parameters, press **Store** key

STORE ENABLE
D.ADJ. PARAMETERS

When parameters have been correctly stored, the LCD displays:

DATA SAVED OK

This concluded DUAL ADJUSTMENT
PARAMETERS setting.

Parameter Settings

Press Mode

Set Dip. Sw. # 1 ON, to advance to:
Energy Save and Slow Speed Modes

**EN. SAVE & SL. SPD
PARAMETERS**

Press Select

Then press ▲ ▼ keys to set Energy Saving Level.
Range: 0-10 (0 = min., 10 = max.)

**SAVING ADJUST.
0 (MIN.)**

Press Select

Then press ▲ ▼ keys to set Slow Speed Torque.
Range: 1-10 (1 = min., 10 = max.)

**SLOW SPEED TORQ.
8**

Press Select

Then press ▲ ▼ keys to set Maximum Slow Speed
Time.
Range: 1-30 sec.

**MAX SLOW SP TIME
30 SEC.**

Press Select

To store selected parameters, press **Store** key

**STORE ENABLE
EN. SAVE & SL. SPD**

When parameters have been correctly stored, the LCD
displays:

DATA SAVED OK

**This concludes ENERGY SAVING / SLOW SPEED
PARAMETERS setting.**

Press Mode

Set Dip. Sw. # 1 ON, to advance to:

FAULT PARAMETERS

Press Select

Then press ▲ ▼ keys to set Phase Sequence trip.
Range: Yes / No

**PHASE SEQ. Y/N
NO**

Press Select

Then press ▲ ▼ keys to set Insulation Alarm.
Range: Off, 0.2 – 5 MΩ

**INSULATION ALARM
OFF**

Press Select

Then press ▲ ▼ keys to set Insulation Trip.
Range: Off, 0.2 – 5 MΩ

**INSULATION TRIP
OFF**

Press Select

Then press ▲ ▼ keys to set Auto.Reset (for Under-
voltage and Phase-loss faults).
Range: Yes / No.

**AUTO RESET
NO**

Press Select

Then press ▲ ▼ keys to set Thermistor Type.
Range: PTC, NTC.

**THERMISTOR TYPE
PTC**

Press Select

Then press ▲ ▼ keys to set Thermistor Trip Level.
Range: Off, 0.1 – 10 KΩ, step: 0.1Kohn.

**THERMISTOR TRIP
OFF**

Press Select

Then press ▲ ▼ keys to set UNDER CUR. RESET
(for temporary Under-currents, in remote installations.)
Range: 10-120Min./OFF.

**UNDER CUR. RESET
OFF**

Press Select

To store selected parameters, press **Store** key

**STORE ENABLE
FAULT PARAMETERS**

When parameters have been correctly stored,
the LCD displays:

DATA SAVED OK

This concludes FAULT PARAMETERS setting.

Parameter Settings

Press Mode

Set Dip Sw. # 1 ON, to Advance to:

**I/O PROGRAMMING
PARAMETERS**

Press Select

Then press ▲ ▼ keys to set Terminal # 7 function

Range: Energy Saver, Slow Speed, Reset

**PROG. INPUT # 7
ENERGY SAVER**

Press Select

Then press ▲ ▼ keys to set Terminal # 8 function

Range: Dual Adjustments, Slow Speed Reverse, Reset

**PROG. INPUT # 8
DUAL ADJUSTMENT**

Press Select

Then press ▲ ▼ keys to set Fault Relay function

Range: Fault, Fault - Fail Safe (Fail-Safe Logic - page 23)

**FAULT RELAY TYPE
FAULT**

Press Select

Then press ▲ ▼ keys to set Immediate Relay function

Range: Immediate, Shear-Pin

**IMM / S.PIN RELAY
IMMEDIATE**

Press Select

Then press ▲ ▼ keys to set Imm / S. Pin Relay On Delay

Range: Immediate 0-60 sec. / Shear-Pin 0-5 sec.

**RELAY ON DELAY
0 SEC.**

Press Select

Then press ▲ ▼ keys to set Imm / S. Pin Relay Off Delay

Range: Immediate 0-60 sec. / Shear-Pin 0-5 sec.

**RELAY OFF DELAY
0 SEC.**

Press Select

Then press ▲ ▼ keys to set Normal or Inverted output

Range: Normal, Inverted

**ANALOG OUTPUT
NORMAL**

Press Select

To store selected parameters, press **Store** key

**STORE ENABLE
I / O PROG. PARAM.**

When parameters are correctly stored, the LCD displays

DATA SAVED OK

This concludes I/O PARAMETER setting.

Press Mode

Set Dip Sw. # 1 ON, to Advance to:

COMM. PARAMETERS

Communication is optional and operates only when starter incorporates this feature.

Note: When using communication and local commands, the last command determines the function.

Press Select

Then press ▲ ▼ keys to specify Communication Protocol.

**COMM. PROTOCOL
MODBUS**

Range: Modbus, Profibus, Modbus-TCP

Press Select

Then press ▲ ▼ keys to set Communication Baud Rate.

Range: 1200-9600 bps

**BAUD RATE
9600**

Press Select

Then press ▲ ▼ keys to set Communication Parity Check. Range: Even / Odd

**PARITY CHECK
EVEN**

Press Select

Then press ▲ ▼ keys to set Communication Serial Link Number.

Range: 1-248 (for up to 32 starters on one twisted pair)

**SERIAL LINK NO.
248 (OFF)**

Note: If communication is not used, serial link number must be set to 248 (Off)

Press Select

To store selected parameters press **Store** key

**STORE ENABLE
COMM. PARAMETERS**

When parameters have been correctly stored, the LCD displays:

DATA SAVED OK

This concludes COMMUNICATION PARAMETERS setting.

Parameter Settings

Press Mode

To Advance to

STATISTICAL DATA
_ ****_

Press Select

To store selected parameters, press **Store** key

LAST STRT PERIOD
NO DATA

Displays last starting time in seconds.

(Time duration until motor's current reached nominal)

Press Select

LAST START MAX I
NO DATA

Displays the maximum current at last start.

Press Select

TOTAL RUN TIME
0 HOURS

Displays motor's hour counter since commencement or since "Statistical Data" was last reset.

Press Select

TOTAL # OF START
0

Displays the total numbers of starts since commissioning or since "Statistical Data" was last reset.

Press Select

LAST TRIP
NO DATA

Describes last fault.

Press Select

TRIP CURRENT
0% OF FLA

Displays the current at the last fault.

Press Select

TOTAL # OF TRIPS
0

Displays the total numbers of trips since commencement or since "statistical Data" was last reset.

Press Select

PREVIOUS TRIPS – 1...9
PHASE LOSS

Displays historical event of the last 1-9 faults, by scrolling with the "▲" or "▼" arrows through the trips stored since commencement or since "Statistical Data" was last reset.

Press Mode to return to Display Only Mode

% OF MOTOR FLA

Service Mode

Press **Mode** and  keys simultaneously, the LCD displays:

STORE ENABLE
DEFAULT PARAMET.

Press Store and **Mode** simultaneously to store factory Default Parameters. All previously stored parameters will be erased. This also returns to "Display Only" Mode.

Or, to Reset Statistical Data:

Press Select

RESET STATISTICS

Press Reset and **Store** simultaneously to reset all your statistical data. This also returns automatically to Statistical Data Mode.

Press Select to see the software program version

Displays program version

PROGRAM VERSION
STRT.DN-020797

Or, for Factory Calibration:

Press Select

Read phase to phase mains voltage.

VOLTAGE ADJUST.
XXX % VOLT

Press Select

Reads current for factory calibration use only.

CURRENT ADJUST.
XX% OF RVS FLC

Press Select

Display goes back to Store Enable Default Parameters

STORE ENABLE
DEFAULT PARAMET.

To exit "Service Mode" press **Mode** +  simultaneously.

NOTES:

- Entering "Service Mode" is possible only when Stop LED is On.
- A Start signal while in "Service Mode" exits from this mode.

Start-Up Procedure

Note: It is necessary to connect a **motor** to load terminals otherwise “Wrong Connection” Protection is activated. Other loads such as light bulbs, resistors, etc. may also cause “Wrong Connection” (Fault).

Start-up procedure with start-stop buttons

1. Connect Control Supply. **On** and **Stop** LEDs will lit.
2. Review all parameters with **Mode** and **Select** keys Set parameters as required.
3. If necessary, return to Default Parameters (see “Service Mode” page 33).
4. Connect mains voltage to starter’s line terminals.
5. Set LCD to show “MOTOR FLA” (% of motor FLA).
6. Press Start. If motor starts to turn shortly after Start signal, proceed to Para 7. If not, increase “Initial Voltage” setting and start again. When, upon starting, initial inrush current and mechanical shock are too high decrease “Initial Voltage” settings and proceed to Para 7.
7. Motor begins to turn. If speed accelerates smoothly to nominal, proceed to Para 8. If current during acceleration is too high, decrease “Current Limit” setting and proceed to Para 8. If motor speed does not accelerate to nominal, increase Current Limit setting.
8. Press Stop and wait until motor stops.
9. Slightly increase Initial Voltage and Current Limit settings to allow for load changes.
10. Press Start and see that motor is Acceleration Time to full speed is as required.
11. If acceleration time is too short, increase “Acceleration Time” setting.
12. Check total starting time and set Max. Start Time to approx. 5 sec. Longer than the maximum time required to complete the starting process.

Examples of starting curves

Light Loads-Pumps, Fans, etc.

Initial Voltage (IV) – set to 30% (Factory Default)

Current Limit (CL) – set 300%

Acceleration Time (AT) – set 5 sec.

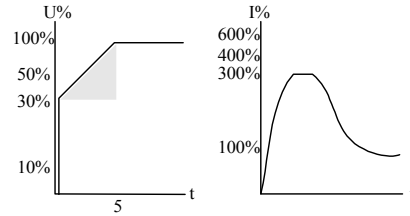

Voltage quickly increases to the Initial Voltage value and then gradually ramps-up to nominal. Current simultaneously and smoothly increases to reach Current Limit setting or less, before smoothly decreasing to the operating current. Motor speed will accelerate to full speed quickly and smoothly.

High Inertia Loads – Fans, Centrifuges, etc

Initial Voltage – set 50%

Current limit – set 400%

Acceleration time– set 20 sec

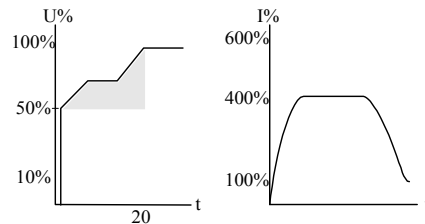

Voltage and current increase until current reaches “Current Limit value”. The voltage is held at this value until motor is close to nominal speed, then current will begin to decrease. The RVS-DN continues to ramp-up the voltage until reaching nominal. Motor speed smoothly accelerates to full speed.

Special starting – Using Dual Adjustment

Using two starting characteristics, the starter will accelerate to DA-IV reaching 100% current limit. After Tx (Imm. Relay delay) voltage to terminal 8 is switched off, using the standard characteristic to complete acceleration. Useful to prevent initial high acceleration. (Applications: Submersible pumps, Drum fans with resonating frequency, etc).

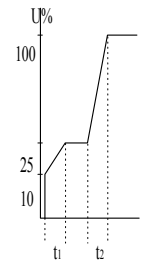

| | Dual Adj. Par. | Standard Par. |
|-------------------|----------------|---------------|
| Initial Voltage | 10% | 25% |
| Acceleration Time | t1 = 2-30 sec | t2 = 2-30 sec |
| Current Limit | 200% | 300-400% |
| Imm.Rel. ON delay | Tx = 1-60 sec. | ----- |

Pump Control

Choosing a suitable **Pump Curve** (centrifugal Pumps)

Starting Curve

1. Adjust main parameters as necessary (FLA, FLC, etc..)
2. Set Starting Curve, Acceleration Time, Current Limit, and Initial Voltage to their default values (curve 0, 10 sec., 400% and 30% respectively).
3. Start the pump while watching the pressure gauge as the pump starts and look for overshooting (“Pressure Surge”) of the gauge needle above the target pressure. In case of over pressure, choose a peak torque reduction curve (Pump Control curve 1!).
4. Set Start Curve 1!, increase Acceleration Time to 15 sec. and reduce Current Limit to 350%. Start the pump and watch the pressure gauge while the pump starts.
5. In most cases, overshooting is reduced, if the overshoot persists, increase Acceleration time to 25 sec. (confirm with motor manufacturer) and try again.
6. If the overpressure persists, increase Starting Curve setting to 2!, 3!, 4 (Torque) or 5 (Current Ramp) if necessary. Each increase in Starting Curve setting will reduce the Peak Torque, thus, reducing the overpressure and preventing the “Pressure Surge” during start.
7. To increase starting time above these maximums, employ “Special Starting” (page 32) with these techniques or incorporate Torque and Current characteristics.

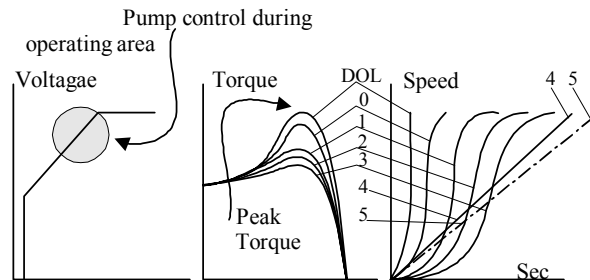

Stopping Curve

1. Adjust main parameters as necessary (FLA, FLC, etc..)
2. Set Stop Curve and Deceleration Time, to their default values (curve 0, 10 sec., respectively).
3. Stop the pump, watching the pressure gauge and the check valve as the pump stops. Look for undershooting/overshooting (“Water Hammer”) of the gauge (which may abruptly stops the pump and the motor).
4. Select Stop Curve 1, increase Deceleration time to 15 seconds. Stop the pump and watch the pressure gauge and the rate of closing of the check valve as the pump stops. Abrupt stopping of the pump and motor will cause a loud audible noise emitted from the check valve.
5. In most cases, “Water Hammer” is reduced. If the “Water Hammer” persists, increase the time to 25 seconds (confirm with motor manufacturer) and try again.
6. If the “Water Hammer” persists, increase Stop Curve setting to 2!, or 3!. Each increase in stop curve will reduce the abrupt stop of the pump, thus, preventing the “Water Hammer” phenomenon.
7. If the extent of the water hammer was not reduced, increase to stop curve # 4 to employ Torque Controlled deceleration.

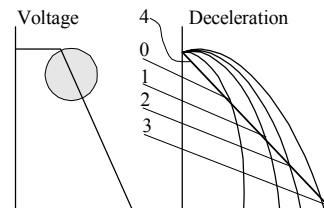

Final torque during soft-stopping a pump motor

1. While decelerating, the check valve may close before Deceleration Time has elapsed, thus, allowing current to flow through stator winding causing unnecessary heat. Select Final Torque sensitivity to 1, and stop the pump, confirm that current stopped flowing through the motor shortly after the check valve closed.
2. If current still flows more than 3-5 seconds after check valve closure, increase Final Torque up to 10 if necessary, to stop current flow earlier.

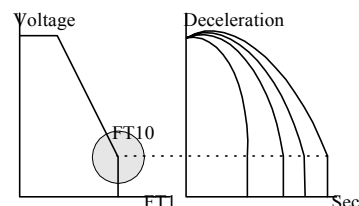

Menu Description

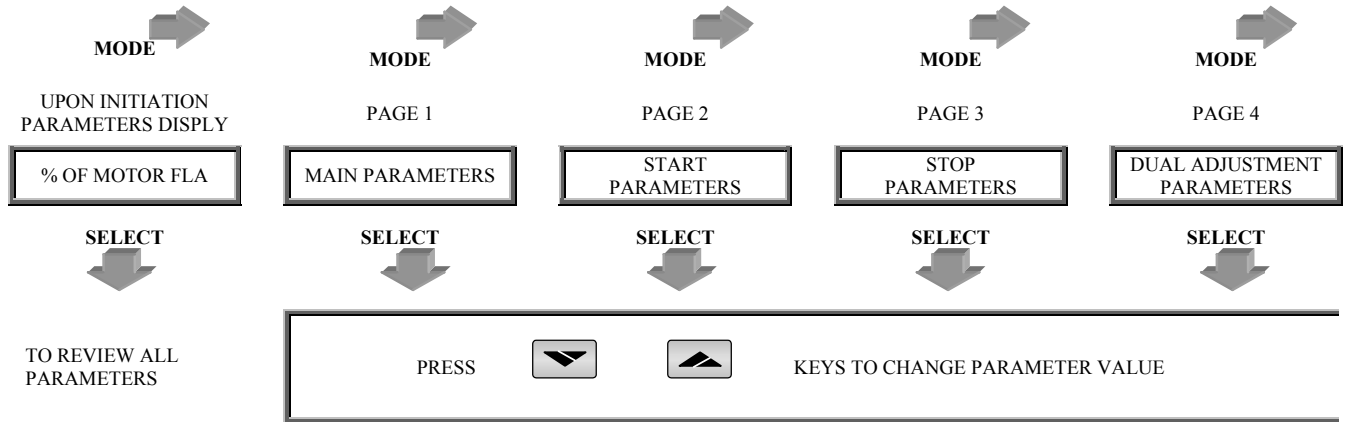

| | | | | |
|-------------------------------|--|-----------------------------------|---|----------------------------------|
| | | When DIP SW# 2 is set ON | | When DIP SW# 3 is set ON |
| % OF MOTOR FLA xx % | CONNECTION TYPE LINE / INSIDE DELTA | SOFT START CURVE 0 (STANDARD) | SOFT STOP CURVE 0 (STANDARD) | DA: INT. VOLT. 30% |
| MOTOR INSULATION 52.8 Mohm | STARTER FLC 105 AMP | START TACHO GAIN 0 (MIN. GAIN) | STOP TACHO GAIN 0 (MIN. GAIN) | DA: GENERATOR PARAMETERS |
| THERMISTOR RES. 3.1 Kohm | MOTOR FLA 105 AMP | SOFT START CURVE 0 (STANDARD) | DEC. TIME 10 SEC. | DA: CUR. LIMIT 400% OF FLA |
| OPTION CARD Not Installed | UNDERCURRENTRIP 0% OF FLA | SOFT START CURVE 1 !! | FINAL TORQUE 0 (MIN) | DA: ACC. TIME 10 SEC. |
| | UNDERCURRENTRIP DELAY 10 SEC. | SOFT START CURVE 2 !! | STORE ENABLE STOP PARAMETERS | DA: DEC. TIME 10 SEC. |
| | O/C – SHEAR PIN 850 % OF FLA | SOFT START CURVE 3 !! | | DA: MOTOR FLA 105 AMP. |
| | O/C DELAY 0.5 SEC. | SOFT START CURVE 4 (TORQUE) | | STORE ENABLE D. ADJ PARAMTERS |
| | OVERLOAD TRIP 115% OF FLA | PULSE TIME 0 SEC. | Note :Available options for “Soft-Start Curve” | |
| | OVERLOAD DELAY 4 SEC – AT 5 FLA | INITIAL VOLTAGE 30% | | |
| | UNDELVOLT. TRIP 300 VOLT | INITIAL CURRENT 100-400% | Note : The “Initial Current” starting Curve becomes available when “Initial Voltage” exceeds 50% (or 80%) | |
| | UNDERVOLT. DELAY 5 SEC. | CURRENT LIMIT 400% OF FLA | | |
| | OVERVOLT. TRIP 480 VOLT. | ACC. TIME 10 SEC. | | |
| | OVERVOLT. DELAY 2 SEC. | MAX. START TIME 30 SEC. | | |
| | STORE ENABLE MAIN PARAMTERS | NUMBER OF STARTS 10 | | |
| | | STARTS PERIOD 30 MIN. | | |
| | | START INHIBIT 15 MIN. | | |
| | | RUN CONTACT DEL. 5 SEC | | |
| | | STORE ENABLE START PARAMTERS | | |



Menu Description

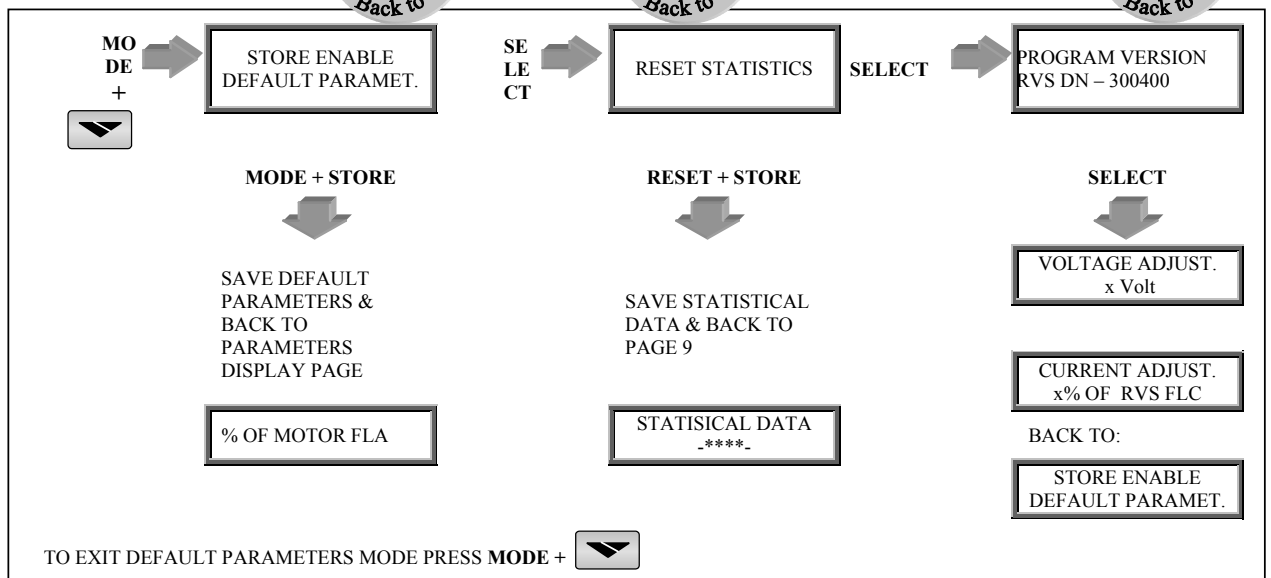
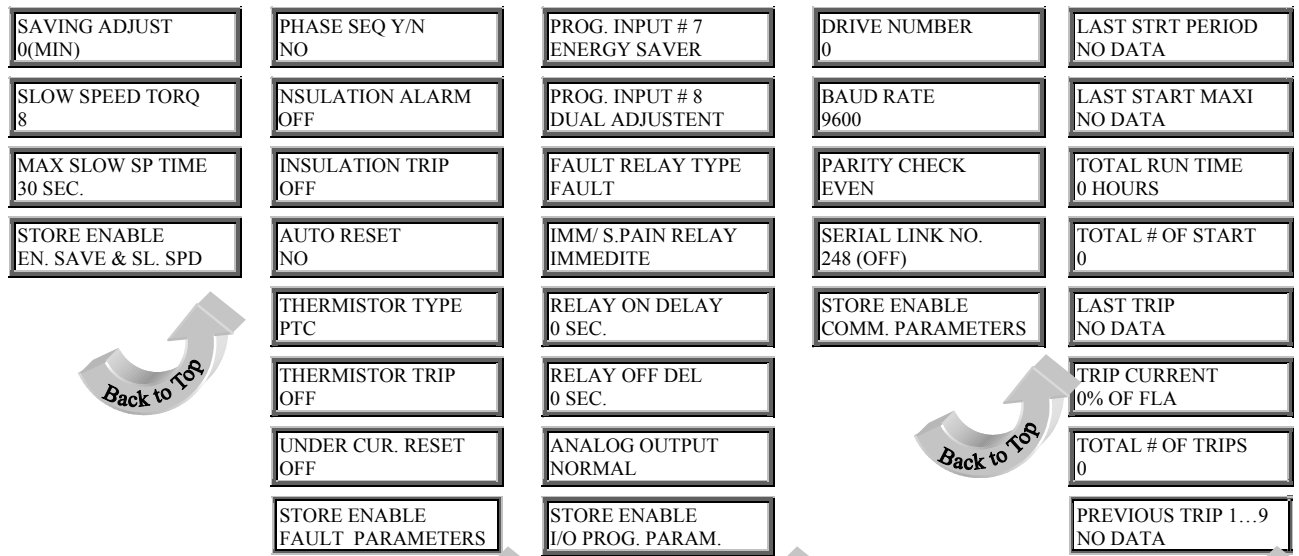
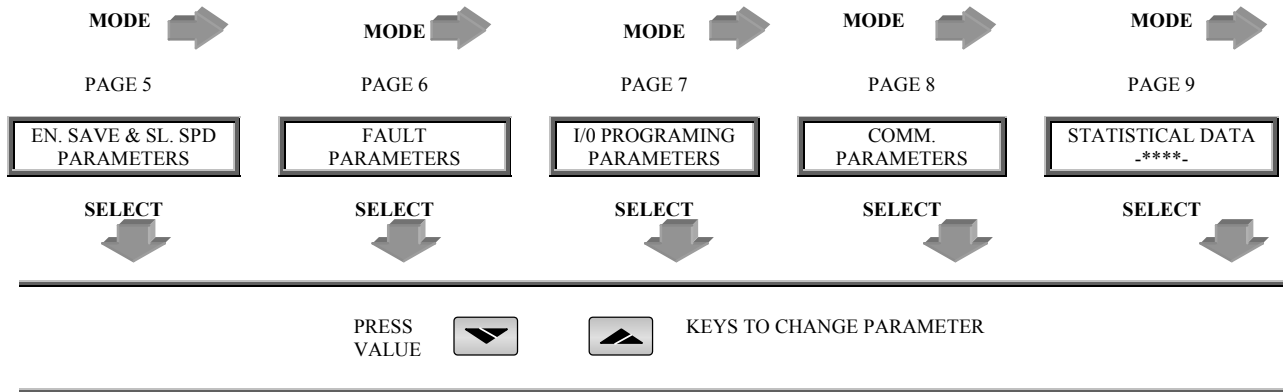

Trouble Shooting

Upon fault – motor stops, Fault LED lights and Fault Relay operates. The LCD shows TRIP: and fault description.
Upon Alarm – motor continues running, Alarm Relay operates and Fault LED flashes. The LCD shows ALARM: and fault description
(for example: **ALARM: MOTOR INSULATION**).

| | |
|-------------------------|---|
| INSULATION ALARM | (Optional) Alarms when motor insulation level decreases below set level. Alarm ceases automatically 60 sec. after resistance able set level. Check motor and cable insulation. |
| INSULATION TRIP | (Optional) Trips the starter when motor's insulation level decreases below trip value. Check motor and cable insulation level. |
| THERMISTOR TRIP | (Optional) Trips the starter when motor's thermistor resistance decreases below trip value. Check thermistor and cable's resistance, check motor temperature near thermistor location. |
| TOO MANY STARTS | Trips the starter if number of starts, during "Start Period" exceeds the preset number. Wait until motor and starter cool down – according to "Start Inhibit" setting. |
| LONG START TIME | Trips the starter if output voltage does not reach nominal at the preset max. Start time. Check FLA, FLC, and Max Start Time settings. Increase Initial Voltage, Current Limit & Max. start time or decrease Acceleration Time as necessary. |
| O/C – SHEAR PIN | <p>Trips the starter when:</p> <ol style="list-style-type: none">1. Instantaneously when current exceeds 8.5 x Starter FLC.2. During starting when current exceed 8.5 x Motor FLA.3. During running when current exceeds 200-850%. <p>O/C Shear-Pin has a programmable delay of 0-5 seconds where the starter detects the fault and does not trip before time delay has elapsed (delay is override when current reaches 8.5 x Starter FLC).</p> <p>Check that motor is not installed or Jammed. Check FLA, FLC settings. Check motor and cable connections. Perform a "Megger" test to verify motor and cable's condition</p> |
| OVERLOAD | Trips the starter when current exceed the Overload Trip level and thermal register has filled up. Check FLA, FLC and Overload settings, check motor current, wait 15 minutes to let motor and starter cool down before restarting. |
| UNDER CURRENT | Trips the starter when line current drops below the preset level for the preset time. Check "Under Current Trip" and "Time Delay" settings, check line currents through L ₁ , L ₂ , L ₃ . |

CAUTION

- Check that "Megger" maximum voltage is no more than 500V!.
- Disconnect terminal 21 before performing a "Megger" test.

Trouble Shooting

| | |
|-------------------------|--|
| UNDER VOLTAGE | Trips the starter when line voltage drops below the preset level for the preset time. Check “Under Voltage Trip “ and “Time Delay” settings, check line voltages on L ₁ , L ₂ , L ₃ . When voltage drops to zero, the starter trips immediately with no delay. |
| OVER VOLTAGE | Trips the starter when line voltage increases above a preset level for a preset time. Check “Over Voltage Trip” and “Time Delay” settings, check line voltage on L ₁ , L ₂ , L ₃ . |
| PHASE LOSS | Trips the starter if 1 or 2 phases are missing. Check line voltages related to terminal 21 is connected correctly (see page 8). Check that frequency variations are between 40-65Hz. |
| PHASE SEQUENCE | Trips the starter if line phase sequence is wrong. Check line phase sequence, and if wrong, swap two wires on <u>line</u> side. If motor now rotates in the wrong direction, swap two wires on <u>load</u> side. |
| MAX SLOW SP TIME | Trips the starter when operating at slow speed for extended period of time. Check that operation time at Slow Speed is shorter than “Max Slow Speed Time” setting. Note: Motor and starter may be overheated when operating at slow speed for an extended period. |
| WRONG CONNECTION | Trips the starter when one or more motor phases is not properly connected to starter’s load terminals or in case of internal disconnection in motor winding. If required, may be eliminated by using Dip Sw # 3 and wiring the soft-starter in generator mode (programming D.A. parameters accordingly*). |
| SHORTED SCR | Trips the starter and prevents starting if any SCR is short-circuited or when motor windings are shorted. Check with an ohmmeter between L ₁ -U, L ₂ -V, L ₃ -W; resistance > 20 KΩ. Check for no voltage on terminals U, V, W (from parallel system or an independent by-pass). SCRs may fail due to: <ul style="list-style-type: none">* High short current not protected by proper fuses* High voltage spikes not protected by proper external Varistors.* Frequent starting at maximum conditions or fault conditions. |
| OVER TEMPERATURE | Heat-sink over-temperature. Trips the starter when heat-sink temp. rises above 85°C. Improve cooling or use a by-pass contactor. Check that motor starting is not too frequent. |
| EXTERNAL FAULT | Trips the starter when a N.O contact between terminals 19-21 closes for over two seconds. Check contact position and cause of closure. |
| WRONG PARAMETERS | Parameters not transferred from RAM to EEPROM or vice versa. After replacing the EPROM with a new software version or after power up, press Reset , than Mode and ▼ simultaneously and save the default parameters by pressing Store and Mode simultaneously. (If Fault LED is on, press Reset after strong parameters). |
| * NOTE: | When operating in generator mode, Shorted SCR and Wrong Connection faults are not active. |

Technical Specification

General Information:

| | |
|--------------------------------|---|
| Supply Voltage | Line to Line 220-690V (to be specified) + 10%-15% |
| Frequency | 45 – 65 Hz (Fixed or variable frequency source) |
| Control Supply | 110-230V (to be specified) +10% - 15% |
| Control inputs & Outputs | Either same as Control Supply or by special order 24-230V AC/DC (to be specified) |
| Load..... | Three phases, three wires, squirrel cage induction motor. |
| Connection type..... | Standard 3 wire U, V, W connection, or 6 wire “Inside Delta” (Programmable) |

Start-Stop Parameters:

| | |
|--|--|
| Starter FLC | Starter’s Full Load Current, according to Selector Guide |
| Motor FLA..... | Motor Full Load Ampere 50-100% of Starter FLC |
| Starting Curve 0 (Standard)..... | 2 Standard Starting and stopping curves. |
| Pump Control Curves (1!, 2!, 3!) | 6 field selectable curves preventing Over-pressure during start and Water Hammer during stop. |
| Torque Control Curve (4)..... | 2 Selectable curves preventing Over-pressure during start and Water Hammer during stop. In addition, these curves may be used for Torque control starting of constant torque applications. |
| Pulse Start Duration | A pulse of 80% Un, for an adj. time 0.1-1 Sec, for starting high friction loads |
| Initial Voltage..... | 10-50% Un (*10-80%), 5% - by special order |
| Initial Current | 100-400% In (1 Current Control starting Curve, appears when Initial Voltage is displayed, “Up” arrow is pressed, and IV% has reached its Max.) |
| Current Limit..... | 100-400% of Motor FLA (*100-500%) |
| Acceleration Time | 1-30 Sec (*1-90 sec) |
| Deceleration Time | 1-30 Sec (*1-90 sec, not in Dual Adjust) |
| Dual Adjustments | Secondary start stop characteristic for: Motor FLA, Initial Voltage, Current Limit, Acceleration Time and Deceleration Time. |
| Energy Saving | Energy save for lightly loaded motors |
| Slow Speed Torque | Torque while motor is at 1/6 nominal speed |
| Tacho and Linear Acceleration | 12 field selectable curves – defining gain control, improving Tacho Feedback. |

* Consult Factory

Motor Protection:

| | |
|--|--|
| Too many starts | Maximum number of starts, range: Off or 1-10, during a time period 1-60 min. |
| Starts inhibit | Time period 1-60 min, when starting is prevented, after Too Many Starts fault |
| Long start time (Stall protection) | Maximum allowable starting time 1-30 sec. (*1-250 Sec). |
| Over current (Shear-pin) | Two operation functions: during starting trips the starter at 850% and during running at 200-850% In, both within 1 Cycle. |
| Electronic overload (I ² t) | Adjustable 75-150% of motor FLA, adjustable Trip time at 500% In of 1-10 sec. |
| Under current..... | Trips when current drops below 20-90% In, time delay 1-40 sec. |
| Under voltage** | Trips when main voltage drops below 120-600V, time delay 1-10 Sec |
| Over voltage | Trips when main voltage increase above 150-750V, time delay 1-10 sec. |
| Phase loss, Under/over Frequency** .. | Trips when one or two phases are missing or frequency is < 40Hz or > 65Hz. |
| Phase sequence | Trips when phase sequence is wrong |
| Long slow speed time..... | Trips if operating at slow speed for more than 1-30 sec (*1-250 sec) |
| Wrong connection | Prevents starting, trips if motor is notconnected / incorrectly connected to the starter. |
| Shorted SCR..... | Trips in case one or more SCRs have been shorted |
| Heat Sink over temperature..... | Trips when heat-sink temperature rises above 85°C. |
| External fault..... | Trips when an External Contact closes for 2 sec. |
| Motor Insulation (optional)..... | Alarm level setting 0.2 – 5MΩ, trips when insulation decreases below 0.2-5MΩ |
| Motor Thermistor (optional) | Trip level setting 1-10KΩ, trips when resistance decreases below the set level. |

- * Special settings – Consult Factory
- ** With optional Auto Reset.

Technical Specification

Control:

| | |
|---------------------------------------|---|
| Displays | LCD in 4 – Field selectable languages and 8 LEDs. |
| Keypad..... | 6 keys for easy setting |
| Aux Contact – Immediate..... | 1 C/O, 8A, 250VAC, 2000VA |
| Aux Contact – End Of Acceleration.... | 1 C/O, 8A, 250VAC, 2000VA |
| Fault Contact | 1 C/O, 8A, 250VAC, 2000VA |
| Insulation Alarm Contact (option).... | 1 C/O, 8A, 250VAC, 2000VA |
| Communication | RS 485 with MODBUS protocol for full control and supervision. |
| | Consult factory for other communication protocol. |

| | |
|----------------------------------|------------------------|
| <u>Temperatures</u> | Operating -10° to 50°C |
| | Storage -20° to 70°C |

Standards:

| | | | |
|---------------------------|--|-------------|---|
| Dielectric Test | 2500VAC | | |
| Degree of Protection..... | IP 20 for frame size A | | |
| | IP 00 for frame sizes B, C, D, E, F, G | | |
| Pollution Degree..... | 3 | | |
| EMC | Emissions | EN 55011 | CISPR 11 Class A |
| | Immunity | EN 55082-2 | ESD 8KV air, IEC 801-2 |
| | | | Electric RF field 10 V/m, 20-1000Mhz, IEC 801-3 |
| | | | Fast transients 2KV, IEC 801-4 |
| | Safety | EN 600947-1 | Related to safety requirements. |
| | | UL508C | |

Normal Service Conditions:

| | |
|---------------|--|
| Altitude..... | Up to 1000m. For equipment to be used at higher altitudes consult Factory. |
| Humidity..... | 95% at 50°C or 98% at 45°C. |

Fan and Starter Consumption Ratings:

| | | | |
|-----------------------|------------------------|---------------------------------|-------|
| Size A (8-31A) | No fan | Total starter Consumption | 150VA |
| Size A (44-72A) | Fan 35 VA | Total starter Consumption | 185VA |
| Size B | Fan 60 VA | Total starter Consumption | 210VA |
| Size C | Fans 105 VA (35VA x 3) | Total starter Consumption | 255VA |
| Size D, E, F, G..... | Fans 150 VA (50VA x 3) | Total starter Consumption | 300VA |

Appendix Table of Contents

| Page | Subject |
|-------------|--|
| 40 | UL and cUL installation instructions, LR recommendations |
| 41 | Fuse selection (A^2S) |
| 42 | Motor and starter Timing Occurrence Table |
| 43 | Warranty Report and Problem Inquiry |
| 44 | “Inside Delta” Description |
| 45 | Overload Trip Time (Approximate calculation) |
| 46-50 | Dimensions and Weights |
| 51 | Block Diagram and Notes |
| 52 | Ordering Information |

UL, cUL Installation Instructions

1. Input power and output motor field wiring shall be copper conductors, rated 75°C.
2. Use UL listed closed-loop connectors sized for the selected wire gauge. Install connectors using the correct crimp tool recommended by the connector manufacturer. Applies only to units bus bars.
3. Table showing corresponding wire size, terminal screw, closed-loop connector size. Torque ratings for attachment of connector to bus bar (see table).
4. Branch circuit protection, shall be provided per the NEC.

For units with UL cUL, see ordering information.

Cables, Terminal screws and Torque recommendations

| No. | Max. Mot. FLA | Min. dimensions for copper cables (mm ²) | Term Screw | Mech. Torq. Kg.cm |
|-----|---------------|--|------------|-------------------|
| 1 | 8 | 3 x 1.5 + 1.5 | | |
| 2 | 17 | 3 x 2.5 + 2.5 | | |
| 3 | 31 | 3 x 6 + 6 | | |
| 4 | 44 | 3 x 6 + 6 | | |
| 5 | 58 | 3 x 10 + 10 | | |
| 6 | 72 | 3 x 16 + 16 | | |
| 7 | 105 | 3 x 50 + 50 | M8 | 180 |
| 8 | 145 | 3 x 70 + 35 | M8 | 180 |
| 9 | 170 | 3 x 95 + 50 | M8 | 180 |
| 10 | 210 | 3 x 150 + 70 | M10 | 220 |
| 11 | 310 | 2 x (3 x 120+ 70) | M10 | 220 |
| 12 | 390 | 2 x (3 x 185+ 95) | M10 | 220 |
| 13 | 460 | 2 x (3 x 240+120) | M10 | 220 |
| 14 | 580 | 3 x (3 x 185+ 95) | M10 | 220 |
| 15 | 820 | 3 x (3 x 240+120) | M10 | 220 |
| 16 | 1100 | | | |
| 17 | 1400 | | | |
| 18 | 1800 | | | |
| 19 | 2500 | TBD | TBD | TBD |

LR Recommendation

LR recommendations for marine, offshore or industrial use.

System design needs to take into account the power supply source and the motor drive together with the electronic soft starter. Particular features to be considered are torque production, harmonic production and their consequential effects and EMC. These points are relevant for marine, off-shore or industrial use.

Fuse Selection (Recommended Values For Main Supply Of 400V)

| RVS-DN Fuse Value | Max. thyristor I ² t Allowed (A ² Sec) | BUSSMAN | Schneider | GEC ALSTOM Ultra Fast Fuse | JEAN MULLER Semicon Fuse | FERRAZ - SHAUMAT | FERRAZ publication Reference / Publication |
|-------------------|--|---------|-----------|----------------------------|--------------------------|--|--|
| RVS – DN 8 | 400 | T.B.D. | T.B.D. | GSGB30 | 500V - 40A | 6,9 Grb 17.32 | A220961 / A60070 |
| RVS – DN 17 | 5,000 | T.B.D. | T.B.D. | GSGB55 | 500V - 50A | 6,9 Grb 17.63 | G220967 / A60070 |
| RVS – DN 31 | 10,000 | T.B.D. | T.B.D. | GSGB110 | 500V - 80A | 6,6 URB 000 BS 88 110 | E330100 / F600397 |
| RVS – DN 44 | 12,000 | T.B.D. | T.B.D. | GSGB125 | 500V - 125A | 6,6 URB 000 BS 88 150 | F330101 / F600397 |
| RVS – DN 58 | 15,000 | T.B.D. | T.B.D. | GSGB150 | 500V - 200A | 6,6 URB 000 BS 88 160 | F330055 / F600397 |
| RVS – DN 72 | 18,000 | T.B.D. | T.B.D. | GSGB170 | 500V - 250A | 6,6 URC 000 BS 88 180 | C330144 / H600399 |
| RVS – DN 105 | 60,000 | T.B.D. | T.B.D. | GSGB225 | 500V - 315A | 6,6 URD 000 BS 88 250 | F330146 / H600399 |
| RVS – DN 145 | 100,000 | T.B.D. | T.B.D. | GSGB350 | 500V - 350A | 6,6 URD 2 x 000 BS 88 355 | V330160 / H600399 |
| RVS – DN 170 | 140,000 | T.B.D. | T.B.D. | GSGB400 | 500V - 400A | 6,6 URD 2x000 BS 88 400 | W330161 / H600399 |
| RVS – DN 210 | 200,000 | T.B.D. | T.B.D. | GSGB450 | 500V - 450A | 6,6 URC 2x000 BS 88 450 | X330162/ H600399 |
| RVS – DN 310 | 600,000 | T.B.D. | T.B.D. | GSGB580 | 500V - 710A | 6,6 URD 31 D 11 0630 | Q300026/ D600188 |
| RVS – DN 390 | 700,000 | T.B.D. | T.B.D. | GSGB710 | 500V - 800A | 6,6 URD 31 D 11 0700 | R300027/ D600188 |
| RVS – DN 460 | 800,000 | T.B.D. | T.B.D. | GSGB800 | 500V - 1000A | 6,6 URD 32 D 11 0800 | W300192 / D600188 |
| RVS – DN 580 | 1,200,000 | T.B.D. | T.B.D. | GSGB900 | 500V - 1250A | 6,6 URD 32 D 11 1250 | B300266 / D600188 |
| RVS – DN 820 | 2,000,000 | T.B.D. | T.B.D. | GSMJ1200 | N.A. | 6,6 URD 33 D 111 400 | C300267 / D600188 |
| RVS – DN 1100 | N.A | T.B.D. | T.B.D. | N.A | N.A | A065URD33LI 1600 OR AO60R1600 or A60X1500A | J301706 / Z600483 OR V479 |
| RVS – DN 1400 | N.A | T.B.D. | T.B.D. | N.A | N.A | A060URD33LI 2000 OR A060R2000 or A60X2000A | J301078 / Z600483 OR |
| RVS – DN 1800 | N.A | T.B.D. | T.B.D. | N.A | N.A | T.B.D. | T.B.D. |
| RVS – DN 2150 | N.A | T.B.D. | T.B.D. | N.A | N.A | T.B.D. | T.B.D. |
| RVS – DN 2400 | N.A | T.B.D. | T.B.D. | N.A | N.A | T.B.D. | T.B.D. |
| RVS – DN 2700 | N.A | T.B.D. | T.B.D. | N.A | N.A | T.B.D. | T.B.D. |
| RVS – DN 3000 | N.A | T.B.D. | T.B.D. | N.A | N.A | T.B.D. | T.B.D. |
| RVS – DN 3500 | N.A | T.B.D. | T.B.D. | N.A | N.A | T.B.D. | T.B.D. |

- Notes:**
1. The above table is for maximum starting current of 500% of FLC, maximum starting time of 30 sec and rated voltage of 400 V (see note 3 for exception).
 2. Rating may change with different external conditions such as ambient temperature, forced cooling etc. Refer to fuse manufacturer catalogs to confirm correct values.
 3. Ferraz ratings are simulated for 4In, 4 times per hour with a 10sec. starting time for each start.

Motor and Starter Protection Occurance Table

| <i>Timing And Occurrence</i> | Active During | | | |
|---|---------------|-----|------|-----------|
| | Start | Run | Stop | Soft Stop |
| Too many starts with Start Inhibit period | √ | | | |
| Electronic Overload with Curve selection | | √ | | |
| Shear Pin (Jam) * Default setting | | | | |
| Starter Protection – trip function at 850% FLC | √ | √ | | √ |
| Motor Protection – trip function | | | | |
| During Start – factory set at 850% FLA in less than 1 cycle. | √ | | | √ |
| During Run – adjust. 200 – 850% FLA within 1 cycle | | √ | | |
| Programmable setting (Dip switch # 2 On) | | | | |
| Starter Protection – trip function at 850% FLC | √ | √ | | √ |
| Motor Protection – Alarm & Trip functions On fault “Immediate Relay” acts as Alarm w/adj. delay – If fault is cleared within the time delay, trip will not occur | | | | |
| During Start – preset at 850% FLA, adjust. delay (Imm. Relay) | √ | | | √ |
| During Run – adjust. 200-850% FLA adjust. delay (Imm. Relay) | | √ | | |
| Under current adjustable time delay | | √ | | |
| Phase Loss | √ | √ | | √ |
| Phase sequence | √ | √ | | √ |
| Under voltage with adjustable time delay. Time delay is overridden in case of “No-Volt”. | √ | √ | | √ |
| Over voltage with adjustable time delay | √ | √ | | √ |
| Long start time (Stall protection) | √ | | | |
| Shorted SCR | √ | | | √ |
| Wrong connection (Load Loss) | √ | | | |
| External fault – input from a N.O. contact | √ | √ | √ | √ |
| SCR protection by Metal Oxide Varistors (MOV) | √ | √ | √ | √ |
| Starter over-temperature | √ | √ | √ | √ |
| Starter internal test, when “On” LED is lit. | √ | √ | √ | √ |
| Motor Insulation test (option) – two levels for Alarm & Trip when installed, operates upon no main voltage | | | √ | |
| Motor Thermistor (option) – programmable PTC/NTC, With adjustable Trip level. | √ | √ | √ | √ |

* Available from software version 5/11/97

Warranty Report and Problem Inquiry – Complete the form and fax for inquiry

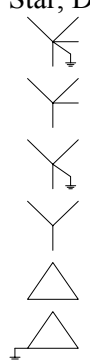
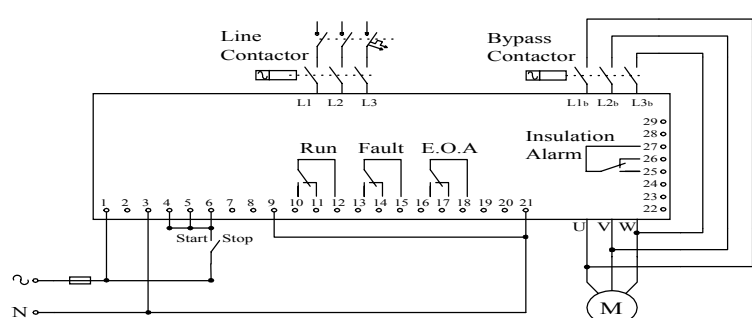
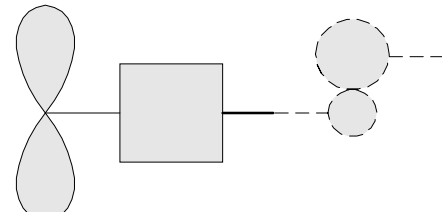
| | | |
|---|--|-------------------------------|
| Representative Name: | Country: | Fax Number: |
| Model Number And Built Options: | Example: 390 – 400 – 230 – 230 – 3 + 4 + 9 + L + A + B – S RVS-DN - - - - + + + + - | |
| Serial Number: | | |
| Purchasing Date: | | |
| Sale / Installation Date: | | |
| Failure Date: | | |
| Program Version: | Press MODE + ∇, press SELECT twice, the LCD displays the program version (e.g. STRT.DN-011197) | |
| <p>Connection Diagram & Supply Network Type. Circle the correct main supply and add or erase parts in the drawing: Star, Delta, with/without neutral or ground</p>   | | |
| <p>Application Description:</p>  | | |
| <p>Details of Fault / Fault Message:</p> | | |
| <p>Define time of fault occurrence: (during start, after start, during soft stop, end of soft stop, when closing B.P. contactor, when performing...)</p> | | |
| Statistical Information | | Starter Operative Information |
| Last Start Period: | | Starter FLC: |
| Last Start Max. I | | Motor FLC: |
| Total Run Time: | | Initial Voltage: |
| Total Number Of Starts: | | Acceleration Time: |
| Last Trip: | | Current Limit: |
| Trip Current: | | |
| Total Number Of Trips: | | |
| Trip History : | | |

“Inside Delta” mode - Description

General information

- Mains current is reduced by 1.73 ($\sqrt{3}$), namely for an 800A motor, an 820A starter will be selected, to operate “In-Line”. For “Inside Delta” starter, we calculate $(800 / 1.73 =)$ and select a 460A starter.
- Less heat dissipates in the cabinet vs. the standard “In-Line” connection.

The attached drawings are for reference purposes only.

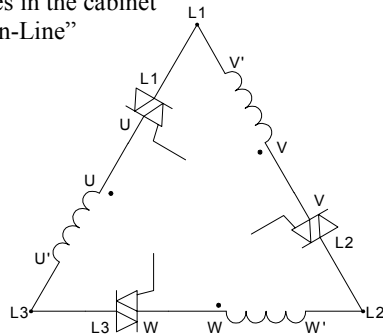

Important Notes:

- **Wrong motor connection will cause serious damage to the motor windings.**
- The sinusoidal shape of the current is imperfect (since each phase is separately fired and not influenced by other phase firing). As a result, higher harmonic content is incurred (THD), which can be as high as twice the THD value as in the standard “In-Line”.
- Higher motor heating is expected for the same motor size (due to the higher THD).
- Phase sequence must be correct; otherwise, “Phase Sequence fault” will trip the starter immediately (without any damage).
- Higher torques can not be obtained
- “Inside Delta” requires 6-wire to the motor.
- Factory preset - features and functions when “Inside Delta” mode is configured:
 - No Pulse Start.
 - No curve selection (Curve 0 !!).
 - No Energy Save
 - No Slow Speed
 - No Phase sequence “Off” mode

Note :

For a high starting torque process, we recommend to use the starter in the “standard” connection (in-line).

Standard Motor Connection Box

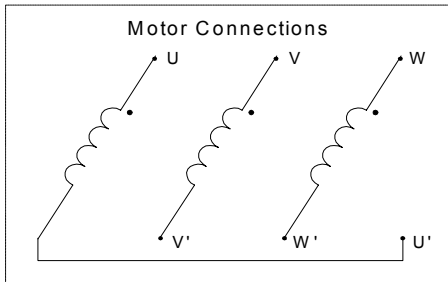

WARNING
Beware

Wrong connection of the starter or the Motor, will seriously damage the motor.

Standard Inside Delta Connection

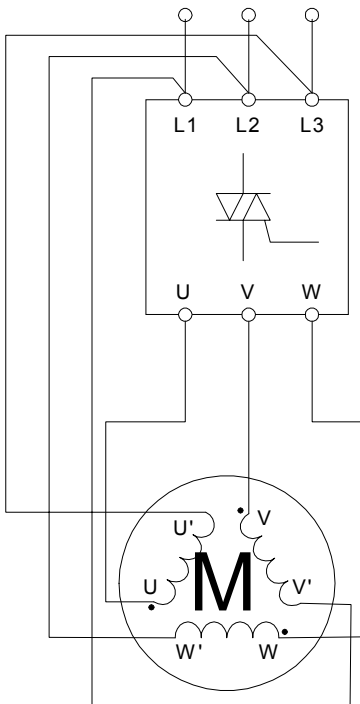

Motor Ratings for In-Line and Inside Delta, at 400V

| Starter Type In Line | Soft-Starter Current (A) | Motor KW @400V “In- Line” | Motor KW @ 400V “Inside Delta” |
|----------------------|--------------------------|---------------------------|--------------------------------|
| RVS-DN 8 | 8 | 4 | 6 |
| RVS-DN 17 | 17 | 7.5 | 12 |
| RVS-DN 31 | 31 | 15 | 25 |
| RVS-DN 44 | 44 | 22 | 38 |
| RVS-DN 58 | 58 | 30 | 50 |
| RVS-DN 72 | 72 | 37 | 64 |
| RVS-DN 85 | 85 | 45 | 75 |
| RVS-DN 105 | 105 | 55 | 95 |
| RVS-DN 145 | 145 | 75 | 120 |
| RVS-DN 170 | 170 | 90 | 155 |
| RVS-DN 210 | 210 | 110 | 190 |
| RVS-DN 310 | 310 | 160 | 275 |
| RVS-DN 390 | 390 | 220 | 380 |
| RVS-DN 460 | 460 | 250 | 430 |
| RVS-DN 580 | 580 | 315 | 540 |
| RVS-DN 820 | 820 | 450 | 770 |
| RVS-DN 1100 | 1100 | 600 | 1000 |
| RVS-DN 1400 | 1400 | 750 | 1300 |

The starter must always be selected according to motor’s nominal current and starting conditions. For “Inside Delta” connection, the “In Line” KW ratings were multiplied by 1.73.

Overload Trip Time Calculation

Note: In overload procedure, current is limited to 5 x Motor FLA to prevent saturation in calculation, so trip time at 5 or 8 times motor FLA will be identical.

The approximate trip time is given in the following equation:

$$\text{O/L Trip Time} = \frac{1,375,000}{I_{\%}^2 - \text{OLT}^2} \times \frac{\text{OLD}}{6} \quad (\text{In Seconds})$$

$$\text{Where : } I_{\%} = \text{Actual Current} \times \frac{100}{\text{Motor FLA}}$$

OLT = Overload Trip setting (default 115%)

OLD = Overload Delay setting – trip delay at 5 x Motor FLA, (default 4 sec).

Example 1: Motor FLA = 80A, actual current = 120A,
 $I_{\%} = 120 \times 100 / 80 = 150\%$
If settings are as in default then

$$\text{O/L Trip Time} = \frac{1,375,000}{150^2 - 115^2} \times \frac{4}{6} = 99 \text{ sec.}$$

Example 2: Same motor and setting, but current is 400A,
 $I_{\%} = 400 \times 100 / 80 = 500\%$
If settings are as in default then

$$\text{O/L Trip Time} = \frac{1,375,000}{500^2 - 115^2} \times \frac{4}{6} = 4 \text{ sec.}$$

Example 3: Motor FLA = 80A, actual current = 200A, Overload Delay (OLD) = 10
 $I_{\%} = 200 \times 100 / 80 = 250\%$

$$\text{O/L Trip Time} = \frac{1,375,000}{250^2 - 115^2} \times \frac{10}{6} = 47 \text{ sec.}$$

Dimensions (mm)

FRAME SIZE - A

8,17A

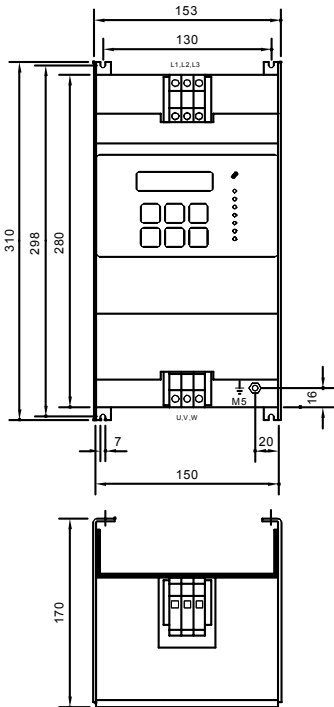

31A

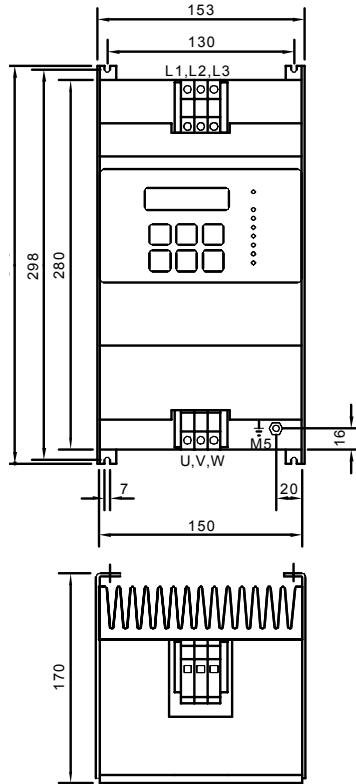

44, 58, 72A

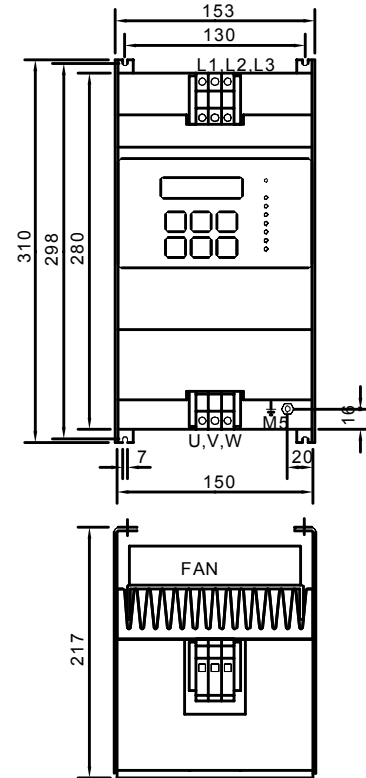

Note: Main voltage terminals size: 8A – 58A - 16mm²
72A - 25mm²

Dimensions (mm)

FRAME SIZE – B (Standard)

105, 145, 170A

Drawing will be delivered upon request

With preparation for by-pass contactor

Drawing will be delivered upon request

FRAME SIZE – B (New – New type includes preparation for bypass as standard)

85, 105, 145, 170A (Deep Type)

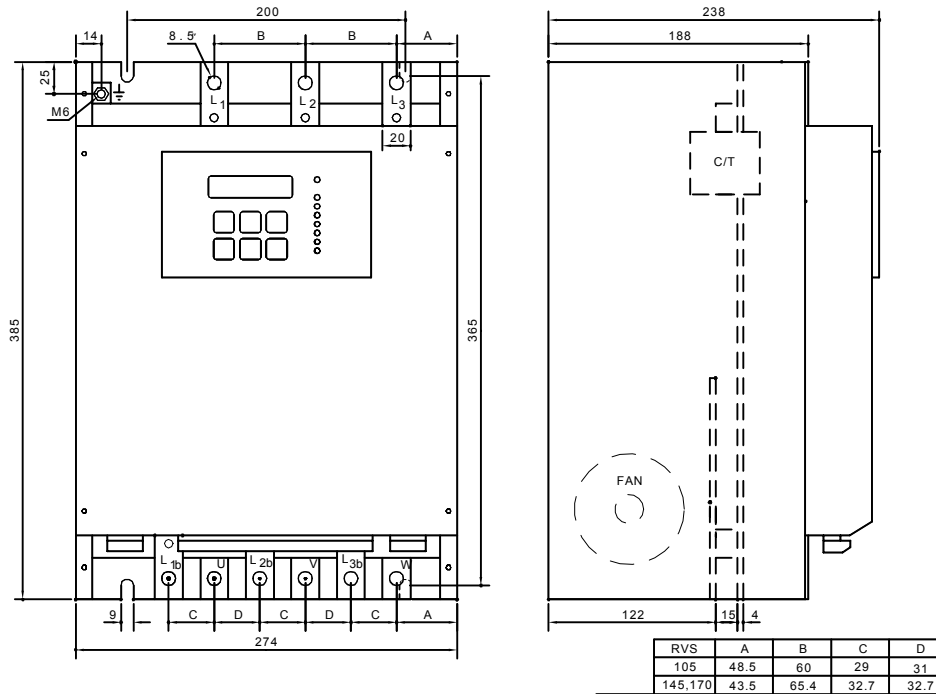

With preparation for by-pass contactor

Notes:

Frame size B (New type, shallow and deep) includes:

1. Preparation for by-pass as standard
2. Line bus bars at the top, Load and By-pass outputs at the bottom.

Dimensions (mm)

FRAME SIZE - C

210, 310, 390A

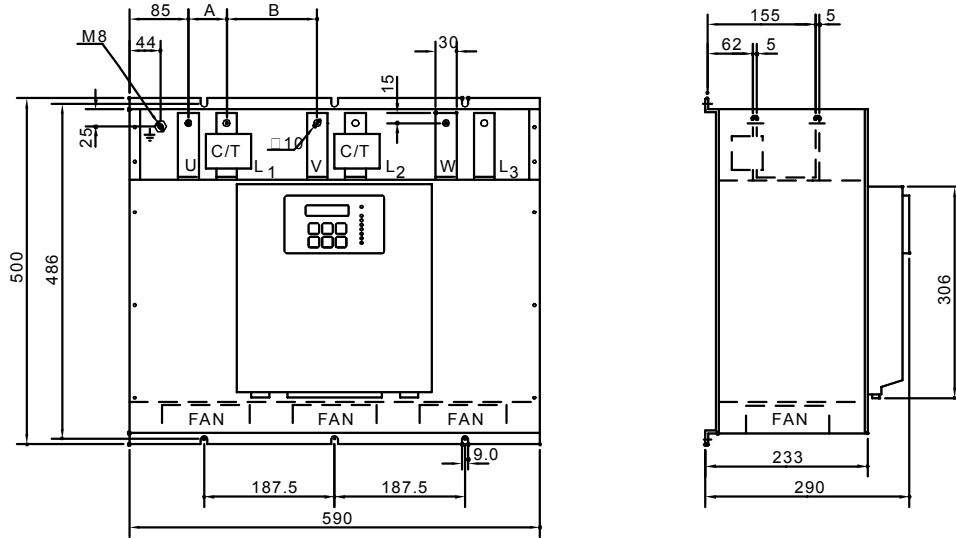

| RVS-DN | 210 | 310 | 390 |
|--------|-----|-----|-----|
| A | 45 | 45 | 55 |
| B | 140 | 135 | 130 |

- The starter can be supplied with line & load bus-bars at the bottom
- The starter can be supplied without side covers, with max width of 536 mm (instead 590)

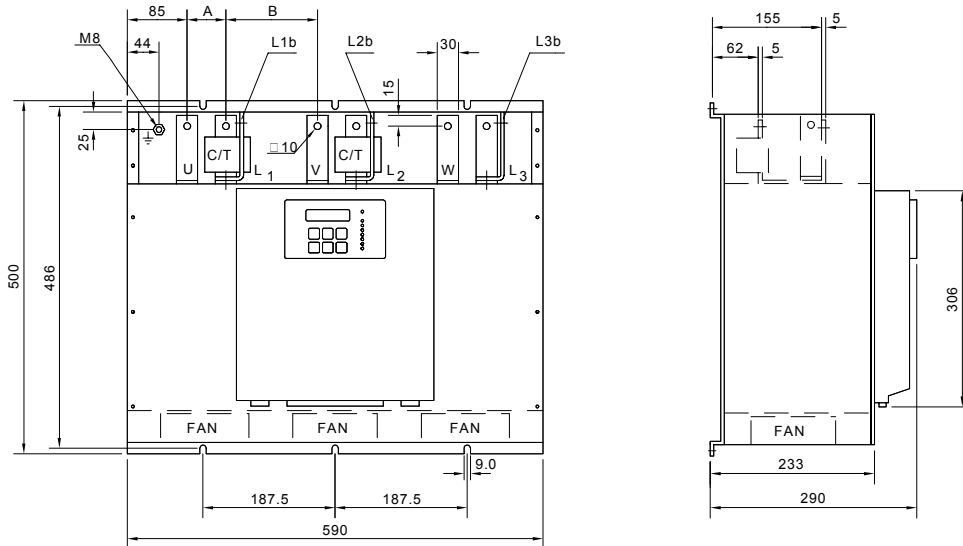

Dimensions (mm)

FRAME SIZE - D 460, 580, 820A

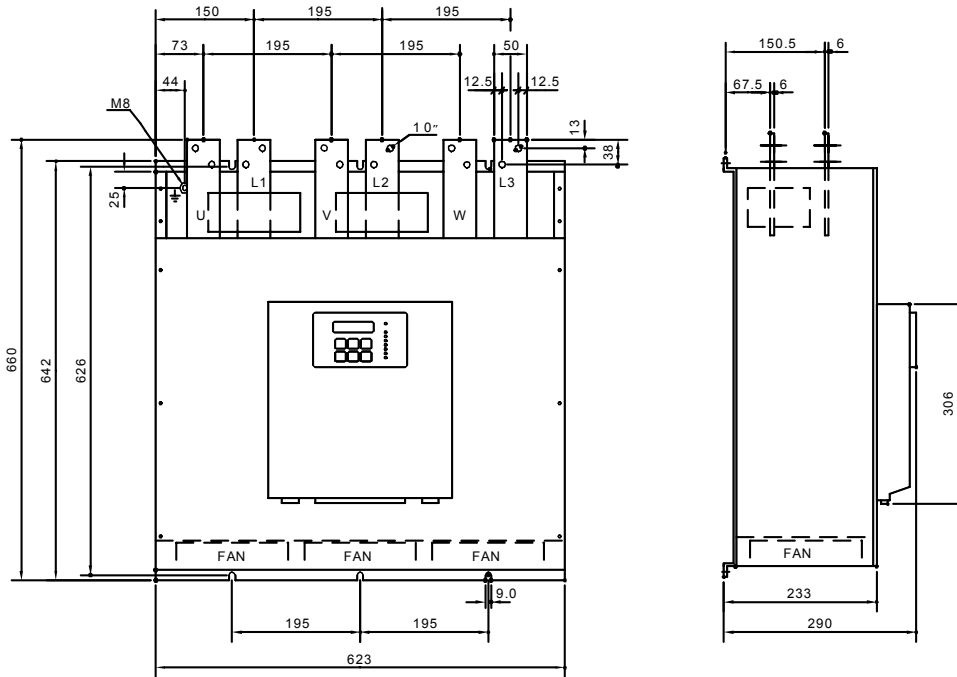

- The starter can be supplied with line & load bus-bars at the bottom

Preparation for by-pass contactor

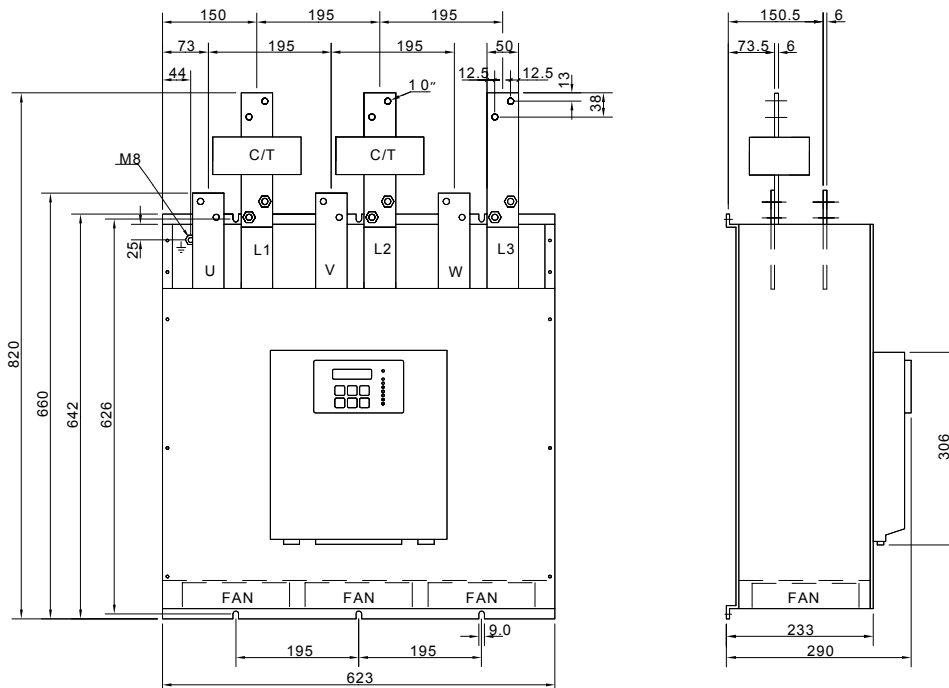

Dimensions (mm)

FRAME SIZE – E 1100, 1400, 1800A

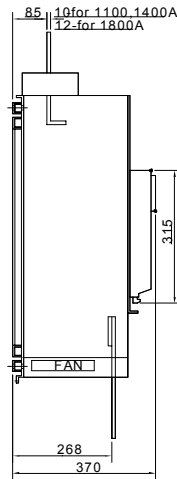
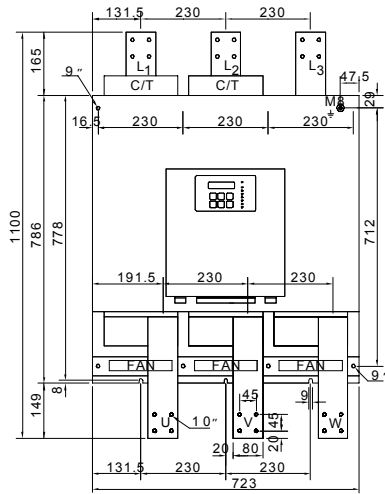

FRAME SIZE – F 2150A

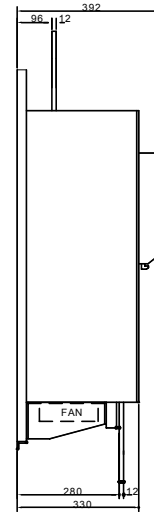
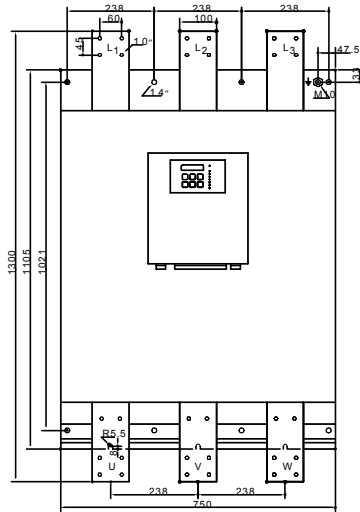

FRAME SIZE – G 2400A, 2700A, 3000A, 3500A

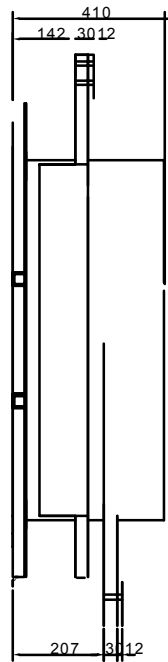
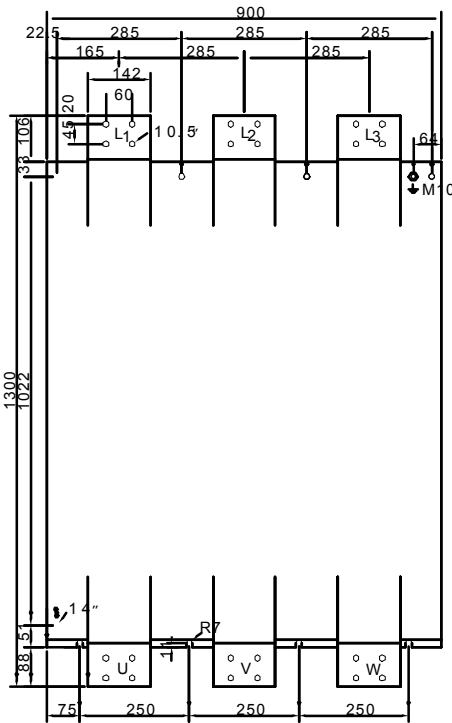

| Starter Type | Current FLC (Amp) | Frame Size | Width | Height | Depth | Weight (Kg.) |
|------------------------|-------------------|------------|-------|--------|-------|--------------|
| RVS-DN | 8, 17 | A | 150 | 310 | 170 | 4.5 |
| | 31 | A | 150 | 310 | 170 | 6 |
| | 44, 58, 72 | A | 150 | 310 | 217 | 7.4 |
| | 105, 145, 170 | B | 274 | 370 | 222 | 15.1 |
| | 210, 310, 390 | C | 590 | 500 | 290 | 44.8 |
| | 460, 580, 820 | D | 623 | 660 | 290 | 65 |
| | 1100, 1400, 1800 | E | 723 | 1100 | 361 | 170 |
| | 2150 | F | 750 | 1300 | 392 | 235 |
| 2400, 2700, 3000, 3500 | G | 900 | 1300 | 360 | 350 | |

RVS-DN Block Diagram

Block Diagram for the RVS-DN control, power and firing module, inputs and option boards.

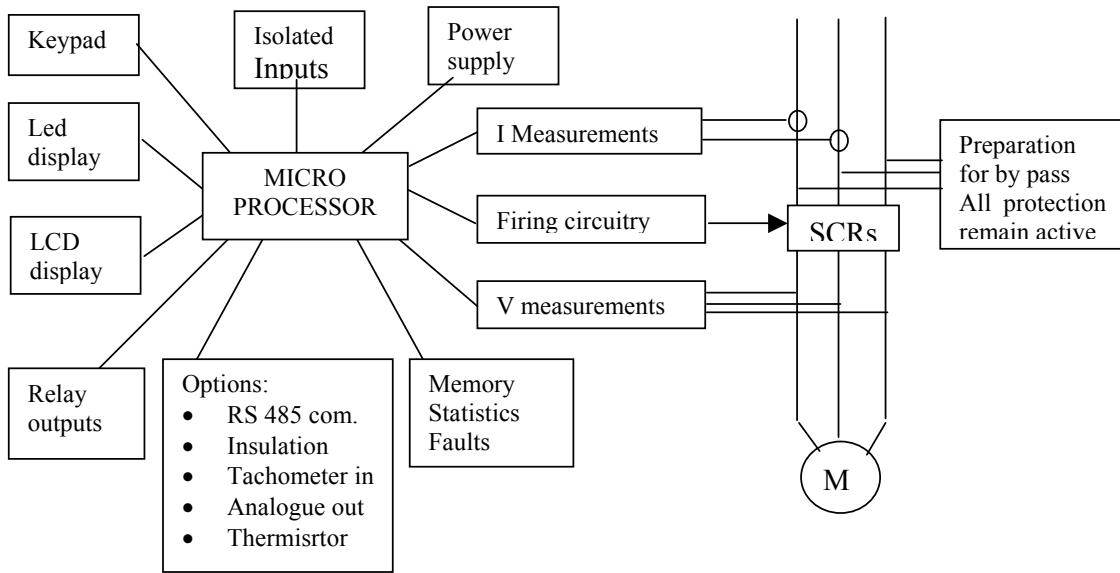

Notes:

| |
|--|
| |
| |
| |
| |
| |
| |
| |
| |
| |
| |
| |
| |
| |
| |
| |
| |
| |
| |
| |
| |
| |
| |

Ordering Information

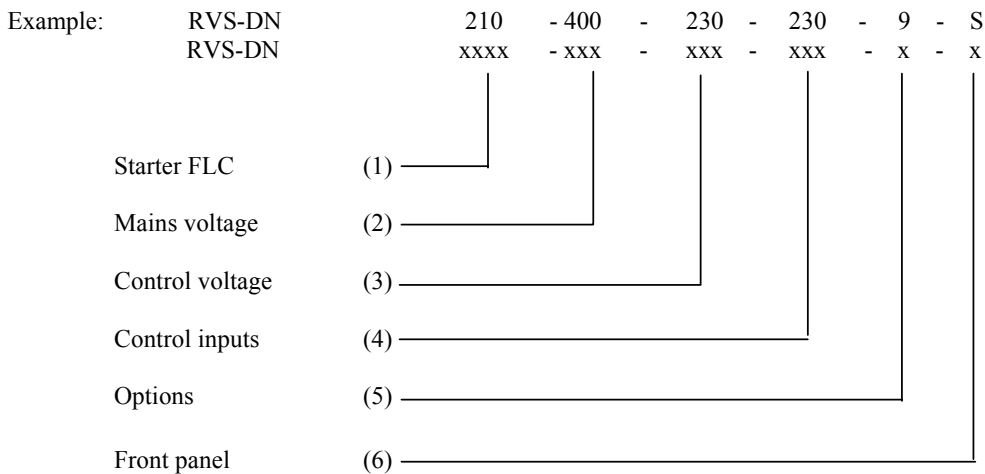

(1) Starter FLC: 8, 17, 31, 44, 58, 72, 85, 105, 145, 170, 210, 310, 390, 460, 580, 820, 1100, 1400, 1800, 2150, 2700, 3000, 3500 Amp

| | | |
|-------------------|----------------|---|
| (2) Mains voltage | <u>Specify</u> | <u>For</u> |
| 50/60Hz | 230 | 220- 240 Vac + 10%-15% |
| | 400 | 380- 440 Vac + 10%-15% |
| | 480 | 460- 500 Vac + 10%-15% |
| | 600 | 575- 600 Vac + 10%-15% |
| | 690 | 660- 690 Vac + 10%-15% |
| | 1000 | 850-1100 Vac + 10%-15% (Special – Please Consult Factory) |

| | | |
|----------------------------|----------------|-----------------------|
| (3) Control Supply Voltage | <u>Specify</u> | <u>For</u> |
| (terminals 1-3) | 115 | 110-120 Vac + 10%-15% |
| 50/60Hz | 230 | 220-240 Vac + 10%-15% |
| | DC | 90-250 Vdc + 10%-15% |

| | | |
|---------------------------|----------------|-----------------------|
| (4) Control Input Voltage | <u>Specify</u> | <u>For</u> |
| (terminals 4-9) | 115 | 110-120 Vac + 10%-15% |
| 50/60HZ or DC | 230 | 220-240 Vac + 10%-15% |
| | 24 | 24- 48 Vdc |

| | | |
|----------------------------|----------------|---|
| (5) Required Options | <u>Specify</u> | <u>For</u> |
| For more than one option | 0 | No options |
| indicate, for example, 3+4 | 3 | Comm. RS-485 (MODBUS, PROFIBUS, MODBUS-TCP) (c) |
| (Comm. + Insulation) | 4 | Insulation tester (b) |
| | 5 | Analogue card – Thermistor in + Analogue out (b) |
| | 8 | Harsh environment treatment (must be factory supplied) |
| | 9 | Preparation for by-pass contactor |
| | A | 536mm special width (for size C only) |
| | B | Line & Load Bus Bars at the bottom (sizes C & D) |
| | D | Remote Panel Mounting replacing the original (with 1.5m cable). |
| | DK | Remote Panel Mounting kit with MMI, option #L and 1.5m cable. |
| | L | Illuminated LCD |
| | M | Lloyd's ENV-1, ENV-2 approval, GL as well (consult factory) |
| | T | Tachometer for special drive systems (consult factory) (b) |
| | U | UL & cUL Approval (8-820A) |

| | | |
|-----------------|----------------|------------|
| (6) Front Panel | <u>Specify</u> | <u>For</u> |
| | S | Standard |

- Notes:** (a) RVS-DN ratings 1100-3500 have to be used with a by-pass.
 (b) RVS-DN size A (8-72A), options should be factory supplied.
 (b) Only one option, either #4, # 5 or # T may be installed in one starter.
 (c) Consult factory for any communication protocol other than MODBUS.