

TECO

MAX^{e3}
PREMIUM
SEVERE DUTY

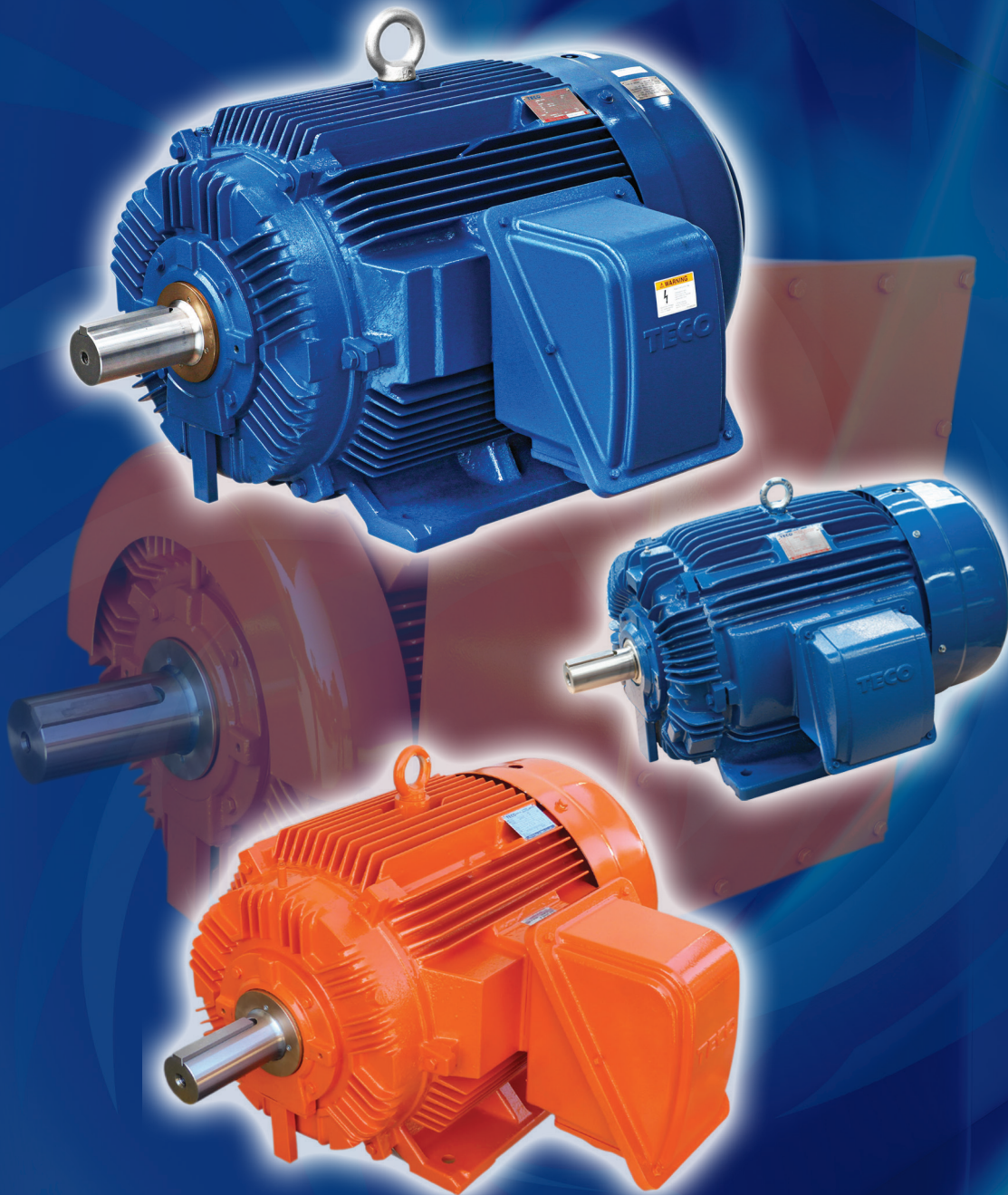

MAX^{e3}
MINING



High Efficiency

Low Voltage 3-Phase | Range
Induction Motors | 0.18kW to 450kW

TOTALLY-ENCLOSED FAN-COOLED CAST-IRON FRAME SERIES



MAXe3 High Efficiency Mobile App
Now available! Refer to page 37 for more details.



Contents

	<i>page</i>		<i>page</i>
Welcome to TECO	1	TECHNICAL DETAILS	
PRODUCT DETAILS		Mechanical Design	
General Information	2	Axial / Radial loadings	20
Electrical Design and Standards		Cooling	21
Altitude	2	Forced Cooling IC416	22
Ambient	2	Mounting (IM code)	23
Direction of Rotation	2	Mounting - Cast Iron Slide Rails (dimensions)	23
Duty Rating	2	Protection (IP code)	24
Electrical Supply	2	Electrical Design	
Motor Types / MEPS	2	Altitude and Ambient Temperature	25
Performance	3	Anti-condensation Heaters (optional)	26
Standards	3	Connection Diagrams	26
Stator and Windings	3	Duty	26
Testing	3	Efficiency	27
Variable Speed Drive Suitability	3	Formulae and Conversion	28
Winding Protection	3	Insulation Classes	29
Mechanical Design and Standards		Speed vs. Torque - Current	29
Balance	4	Starts per Hour	30
Bearing and Lubrication System	4	Maximum Load Inertia	30
Bearing Lubrication Instructions	5	Thermal Protection	31
Bearing False Brinelling Protection	5	Thermistors	31
Cooling System	6	Resistance Temperature Detectors	32
Finish	6	Tolerances for electromechanical characteristics	33
Hardware	6	Variable Speed Drives (VVVF)	34 ~ 35
MAXe3 - Mining Spec "HX" Motors	6	Voltage and Frequency during operation	36
Mounting	6		
Motor Construction	6		
Protection	6		
Rating Plates	6		
Rotor Assembly	7		
Maximum Cable Sizes	7		
Terminal Box	7-8		
Options	8		
Performance Data - High Efficiency MAXe3 Range 63 - 315M	9 ~ 10		
Outline Dimensions - Frame 63 - 132 Foot Mount	11		
Outline Dimensions - Frame 160 - 250 Foot Mount	12		
Outline Dimensions - Frame 280 - 315M Foot Mount	13		
Outline Dimensions - Frame 315A - 355 Foot Mount	14		
Outline Dimensions - Frame 63 - 132 Flange Mount	15		
Outline Dimensions - Frame 160 - 250 Flange Mount	16		
Outline Dimensions - Frame 63 - 200 Foot and Flange Mount	17		
Outline Dimensions - Frame 225 - 315M Foot and Flange Mount	18		
Outline Dimensions - Frame 63 - 132 Foot and C Face Mount	19		



Welcome to Teco!

Welcome



TECO Australia – Electric Motor Division

Established in 1983 as a wholly owned subsidiary of TECO Electric & Machinery Co., TECO Australia has earned a reputation as a reliable supplier of superior quality Electric Motors, Variable Speed Drive systems and Motor Controls. These products are all designed, manufactured and tested to meet stringent Australian and International Standards.

TECO Electric Motors are regarded as one of the leading brands available on the market and are regularly specified and preferred by equipment manufacturers, constructors, engineering companies and major end-users alike.

TECO Electric & Machinery Co.

From modest beginnings in 1956, TECO Electric & Machinery Co. has grown to be one of the world's largest manufacturers of an extensive range of electric motors. In addition to the core manufacturing facilities in Taiwan, the continual growth of TECO on a global front has seen the formation in 1995 of the TECO Westinghouse Motor Company in the USA, borne out of the 100% ownership of the Westinghouse Motor Company along with the establishment of additional major manufacturing facilities around the world to service new markets and meet global demand.

TECO Westinghouse

TECO designs and manufactures a complete range of low, medium and high voltage motors, Variable Speed Drives and Control Gear with sales and support being offered on a global basis.

Quality Assurance

All TECO manufacturing plants and TECO Australia have been assessed to meet the requirements of ISO9001 documented quality systems.

TECO Sydney facility is also an IECEx listed manufacturer for Ex d, Exde, Ex e, Ex nA and Ex tD hazardous area motors, having obtained an IECEx QAR from TestSafe Australia.

From our overseas factories to our local offices, TECO ensures the highest quality throughout the entire supply chain.

Environmental and RoHS

TECO major manufacturing plants in Taiwan have ISO14001 Environmental Management System accreditation.

Low Voltage motors manufactured by TECO do not contain (or contain within the maximum allowable limits) any restricted hazardous substances as per European Directive 2002/95/EC(RoHS).





Driving & Connecting Globally



TECO MAXe3 Range of HIGH EFFICIENCY MOTORS.

The new **MAXe3** range of High Efficiency motors have been specifically designed, manufactured and tested by TECO to excel in the most arduous conditions encountered by the Australian mining sector, heavy industries and in other demanding environments.

Motors are protected to IP66 and rated to 55°C (Severe Duty) or 60°C (Mining) ambient to outlast in the harshest Australian conditions.

General Information

The motors described in this catalogue are designed and manufactured by TECO Electric & Machinery Co. and are Squirrel Cage Induction Motors intended for industrial and arduous mining applications and meet all relevant sections of the Australian, New Zealand and International Standards detailed herein.

Electrical Design and Standards

Altitude

Designed for operation at an altitude up to 1000 metres above sea level, refer to page 25 for higher altitudes.

Ambient

Motors are designed to operate at rated nameplated kW in ambient conditions of -20°C to maximum ambients as detailed below.

Motor Type	Ambient
MAXe3 MINING	60°C
MAXe3 PREMIUM SEVERE DUTY	55°C

Direction of Rotation

Standard rotation is clockwise when viewed from the drive end with the terminal marking corresponding to incoming line markings.

Duty Rating

All motors have a maximum continuous duty rating of S1 to AS60034-1. TECO MAXe3 motors have a generous Service Factor, enabling overload, as detailed below, in a 40°C ambient.

Motor Type	Service Factor
MAXe3 MINING	1.2
MAXe3 PREMIUM SEVERE DUTY	1.15

Electrical Supply

Stock motors are designed for operation on a 380-415 Volt 3-Phase 50 Hz supply and are also suitable for a 440-480 Volt 3-Phase 60 Hz supply.

Motors 4 kW and below are 380-415 Volt 50 Hz STAR connected and may also be reconnected to 240 Volt 3-Phase 50 Hz DELTA configuration for use with single-phase input inverters.

Motors 5.5 kW and larger are 380-415 Volt 50 Hz DELTA connected.

Please refer to page 26 for Connection diagram.

Motors can be manufactured for supply systems of up to 1100 Volts, 50 or 60 Hz on a factory made to order basis or by local rewind / wind.

Motor Types / MEPS (Minimum Efficiency Performance Standard)

TECO MAXe3 motors (AEMB and AFJE) exceed the High Efficiency requirements from Greenhouse and Energy Minimum Standards (GEMS) acts and regulations. Within the range of 0.75 kW to 185 kW, 2 to 8 poles, these motors also comply with IE3 efficiency level of IEC60034-30-1 standard, when operating at 50 Hz, single speed, and direct on-line.

TECO MAXe3 HIGH EFFICIENCY



Providing the best
payback periods
and the lowest total
cost of ownership

Performance

Motors are designed to meet the performance requirements of Design N as per AS60034-12, normal torque for Direct-On-Line starting.

Motors are also suitable for other means of starting, depending on load characteristics, please refer to TECO.

Other performance characteristics can be manufactured to suit any special requirement.

Standards

Motors are designed, manufactured and tested in accordance with AS1359/AS60034-12. Frame sizes comply with IEC 60072-1.

Motors also meet the requirements of European Directives where applicable and are CE marked.

TECO has a "Declaration of Conformity" and is a registered user of "C-tick" number N121, which covers TECO squirrel cage induction motors.

For other foreign standards i.e. UL, CSA etc., please refer to TECO.

Stator and Windings

The stator is made up of exceptional high grade, low-loss insulated cold rolled electro magnetic silicon-steel laminations for maximum efficiency and low core losses.

Windings are random wound with spike resistance Class H copper wire, impregnated with a solventless resin and are tropic-proof rated as standard. Motor types are insulated as detailed below.

Motor Type	Insulation system
MAXe3 MINING	Class H
MAXe3 PREMIUM SEVERE DUTY	Class F

Windings are designed with a temperature rise of less than Class B (80°C) and, in most cases are less than Class E (75°C) for long motor life, providing massive thermal reserve.

Please refer to page 29 for Thermal Reserve.

Testing

In addition to a full program of tests during manufacture each motor is subjected to routine tests to AS60034-1 prior to despatch. Performance testing (witnessed or unwitnessed) can be arranged for factory made to order motors.

Variable Speed Drive (VSD) Suitability

Motors are suitable for VSD operation, (subject to torque and speed limitations), depending on the load characteristics and correct installation of motor and drive.

For Variable torque loads (centrifugal pumps and fans) for speeds between 5-50 Hz derating is not normally required.

Force cooling units are also available when necessary (please refer to page 22 for forced cooling details and page 34-35 for VSD speed range and insulation ratings).

Electro-discharge machining of motor bearings can be a concern in some applications with larger motors on VSD's (please refer to page 35 for our recommended preventative measures).

Winding Protection

Motors frame size D160 and larger are fitted with PTC thermistor protection within the windings (one per phase) with the leads terminated in the main terminal box as detailed below.

Motor Type	Thermistors fitted
MAXe3 MINING	P180 (Trip) + P150 (Alarm)
MAXe3 PREMIUM SEVERE DUTY	P150

Motors 185 kW and larger have thermistor leads terminated in an auxiliary terminal box (available on smaller motors on request).

Mechanical Design and Standards

Balancing and Vibration

All rotors are dynamically balanced with a half key to grade G2.5 according to ISO21940 standard, so the motor vibration complies with grade A of IEC60034-14 standard. Alarm and trip vibration values for motors mounted in situ depend on the application conditions, so please refer to ISO20816 standard.

Bearing and Lubrication System

Frame Size	Poles	DE Bearing	NDE bearing	Greasing/ Shaft Seal
D63 ~ D90L	2	Ball	Ball	Greased for life/ Gamma***
D100L ~ D160L	2	Ball	Ball	Greased for life (GR)/ Gamma***
D180M ~ D250M	2	Ball	Ball	Grease relief
D280S ~ D355*	2	Ball	Ball	Grease relief brass dust flinger
D63 ~ D90L	4 and Above	Ball	Ball	Greased for life/ Gamma***
D100L ~ D132M	4 and Above	Ball	Ball	Greased for life (GR)/ Gamma***
D160M ~ D180M/L	4 and Above	Ball (Roller)	Ball	Greased for life (GR) / Gamma***
D200L ~ D225M	4 and Above	Ball (Roller)	Ball	Grease relief/ Gamma
D250S ~ D250M	4 and Above	Roller (Ball)	Ball	Greased relief/ Gamma
D280S ~ D315M	4 and Above	Roller (Ball)	Ball	Grease relief/ brass dust flinger
D315A ~ D355*	4 and Above	Ball**(Roller)	Ball	Grease relief/ brass dust flinger

Key: (options in the parentheses are alternatives)

GR = Grease Relief

* Larger sizes also available, refer to TECO for details.

** Ball bearing fitted for direct drive, Roller can be fitted for Belt Drive applications, please refer to TECO. MAXe Mining have a roller at drive end as standard.

*** Oil Seal fitted to flange/Cface.

C3 diametrical clearance bearings are fitted to all MAXe3 motors for long life and optimum reliability in service.

- 2 Pole motors up to and including D180 are suitable for both direct drive and belt drive applications.
- 2 Pole motors D200 and larger are typically suitable for direct drive only. For belt drive above D200 please refer to TECO.
- 4 Pole and larger; up to and including D315MC (AEMB) motors are suitable for Belt Drive or Direct Drive.
- Frames D315A to 560 (AFJE) are suitable for direct drive, for Belt Drive refer to TECO.

TECO Flush Through Grease Relief Bearing System with Gamma Seal Up to D250 frame.

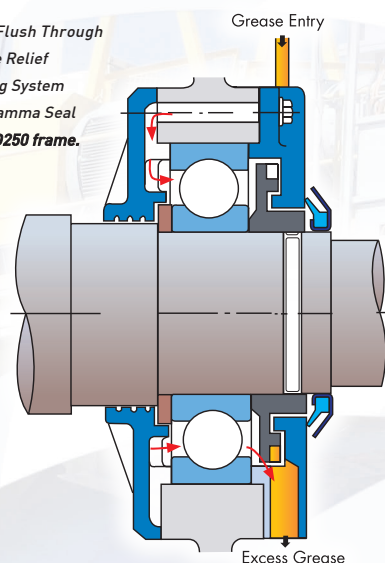

TECO Flush Through Grease Relief Bearing System with Brass Dust Flinger D280-355 frame

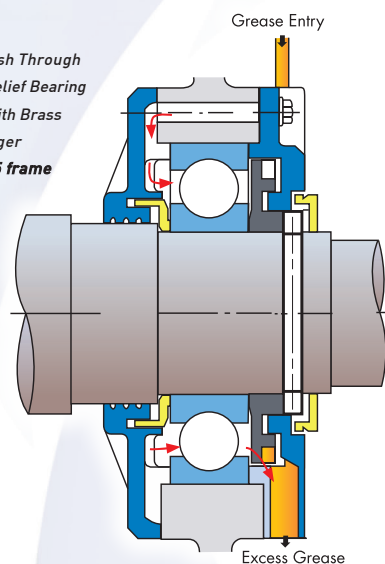

The TECO Flush Through Grease Relief Bearing System gives positive displacement of old grease and is designed for re-greasing during operation.

The fitment of rotating inner & outer labyrinth seals achieves effective sealing from ingress of contaminants.

This is a true pressure grease relief system where the grease enters the back of the bearing then is forced through to the front and is expelled through a large external discharge chute.

This system will not allow over-greasing to affect the performance of the bearings. This type of grease replenishment system will not allow contaminants to be pushed back into the bearing itself, which, if allowed, can cause premature bearing failure.

Bearing Lubrication Instructions

Table 1: Bearing Grease Schedule - 50Hz Operation (bearing temperature 70°C)-Hours

Bearing Number	8 Pole	6 Pole	4 Pole	2 Pole	
62XX	10	17500	15500	12500	6000
63XX	11	17000	15000	11500	5500
72XX	12	16500	14500	11000	4500
73XX	13	16000	14000	10000	4000
	14	15000	12500	9000	3500
	15	15000	12500	9000	3000
	16	14500	12000	8500	2500
	17	14000	11500	8000	2500
	18	13500	11000	7500	2500
	20	12500	10000	6000	
	22	11500	9000	5500	
	24	11000	8000	4500	
	26	10000	7500	4000	

Bearing Number	8 Pole	6 Pole	4 Pole	
NU2XX	14	12000	9500	6000
NU3XX	15	11500	9000	5500
	16	11000	8500	5000
	17	10500	8000	4500
	18	10000	7500	4000
	20	9000	6000	3000
	22	8000	5500	2500
	24	7000	4500	2000
	26	6500	4000	1500

Table 2: Bearing Grease Fill

Bearing Number	Amount (Grams)	Bearing Number	Amount (Grams)		
62XX	6210	30	63XX	6310	40
	11	35		11	50
72XX	12	40	73XX	12	60
NU2XX	13	50	NU3XX	13	80
	14	50		14	80
	15	60		15	100
	16	60		16	100
	17	80		17	120
	18	80		18	120
	20	100		20	160
	22	120		22	220
	24	120		24	270
				26	300

Grease

Super-premium Mobil Polyrex™ EM Series grease is specially formulated for electric-motor bearings. The advanced thickener formulation and proprietary manufacturing techniques provide improved bearing performance and protection for long electric motor life.

- Notes:**
1. Please ensure bearings are fully purged during commissioning, thereafter, adhere to the above re-greasing schedule.
 2. Replenishment of grease recommended when motor is running.
 3. Do not mix dissimilar greases.

Features and Benefits

- Outstanding grease life, outstanding long-life, high-temperature lubrication of ball and roller bearings
- Advanced polyurea thickener.
- Increased durability versus conventional polyurea greases when subjected to mechanical shear forces.
- Excellent corrosion resistance providing protection against rust and corrosion.
- Protection under mild salt-water wash conditions.
- Low-noise properties.

When do motors require greasing?

- At initial start during commissioning.
- If the motor has been out of service for three (3) months or longer.
- At predetermined intervals, please refer to "Table 1".

What to do prior to greasing?

- Check the motor nameplate for the type of grease and check that the grease you plan to use is fully compatible.
- Clean the grease nipples on the motor and the grease gun discharge connection.
- Ensure that the grease discharge chute on the motor is clean and not blocked with old hard grease.

How to effectively grease an electric motor?

- The electric motor must be running with preferably the bearings up to normal operating temperature.
- Pump-in half of the required quantity of grease as in "Table 2" to each bearing and allow to settle.
- After 5-10 minutes pump-in remainder of the required grease quantity.
- Please note, it is normal to see an increase in the bearing temperature during the greasing procedure.
- Expelled grease should be evident at the rotating labyrinth seal and within the discharge chute.
- 30 minutes after the greasing procedure the bearing temperatures should return to normal, if not, please check that there are no other reasons for an increase in bearing temperature, i.e. misalignment, high vibration etc.

Bearing False Brinelling Protection

A bearing, will experience false brinelling when it is not turning and subjected to vibrations. This is generally in the cylindrical roller type and brought about by transportation of the motor without an effective shaft lock to prevent movement or from vibration of the motor when de-energized. Because the bearing is not turning, the grease or oil will be gradually removed from the ball or roller contacts ending in metal to metal contact. Wear is then allowed to take place and the damage will cause the bearing to fail prematurely after start up. TECO fit shaft locks on D180 2 pole ~ D200 4 pole and larger to prevent false brinelling.

Please ensure motors are transported and stored with their shaft clamps attached.

Extensive shaft locking clamp on large AFJE motor



Cooling System

Motors are Totally Enclosed Fan Cooled (TEFC), with integrally cast cooling fins on frame and endshields, fitted with external fan (IC411) to AS1359.106.

The cooling fans are bi-directional and low noise as standard (2 pole 220 kW and larger have uni-directional fans only).

Finish

All external components are shot blast to a near white finish. A durable coat of Alkyd Resin primer giving excellent corrosion protection follows this preparation. The complete motor is then finish coated with Alkyd Resin Gloss Enamel, finish Colour as per table below.

Motor Type	Finish Colour
MAXe3 MINING	Orange (X15 AS2700)
MAXe3 PREMIUM SEVERE DUTY	TECO Westinghouse Blue (Munsell 5PB3/8).

Other paint systems and colours are available upon request, including chemical duty two-pack polyurethane and epoxy paint systems.

Hardware

All hardware is electro zinc plated for better corrosion resistance.

Stainless steel hardware can be offered as an alternative, please contact TECO for the surcharge to provide this feature.

MAXe3 MINING "HX" Motors Arduous Mining Crusher Duty Frames D315MC to D355

These are a special range of motors, which meet the High Efficiency levels and also have the following extra features as standard:

- Oversized drive end shaft and bearings for demanding belt drive applications.
- Two sets of thermistors providing an alarm and trip set with auxiliary terminal box.
- Oversized Fabricated Steel primary terminal box with non-ferrous blank gland plate.

Mounting

Motors are available in the following mountings, refer to page 23 for IM codes of mountings.

- Foot-mounted
- Foot and Flange mounted
- Flange-mounted
- Foot and C Face-mounted
- C Face-mounted

Motor Construction

Motor frames are high grade Cast Iron with integrally cast feet and cast iron end shields, suiting mining applications.

Castings are machined to close tolerances in order to ensure accurate alignment with minimum vibration.

Standard Materials of Construction

Frame Size	MAXe3 MINING	MAXe3 PREMIUM SEVERE DUTY	Fan Cover	Terminal box
	External Fan	External Fan		
D80-D132	CPP (CI)	CPP (CI)	HDPS (CI)	CI
D160-D315M	CI	CPP (CI)	HDPS (CI)	CI
D315A-D355*	FS	CPP (FS)	FS	FS*(CI)

Key: (material in parentheses is alternative)

CPP – Conductive Polypropylene (Non Sparking)

CI - Cast Iron

HDPS - Heavy Duty Pressed Steel

FS - Fabricated Steel

FS* - Fabricated Steel with blank cable entry gland plate.

* Larger sizes are also available, please refer to TECO for details.

Protection (IP rating – stock motors)

All motors are rated IP66, thereby providing excellent protection against the ingress of dust and water. Sintered Bronze (screwed in stainless holder) porous drain plugs are fitted to all Foot and Foot / Flange mounted motors, intended for Horizontal mounting and can be included on Flange mount motor on request.

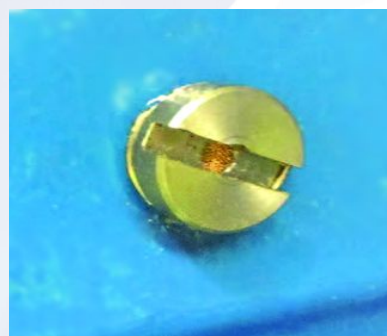

Rating Plate

A stainless steel rating plate containing all details as specified in AS60034-1 [including bearing sizes] is fitted to all motors. The rating plate also confirms compliance with MEPS Efficiency Standard.

TECO MAXe3 MINING HIGH EFFICIENCY MOTORS	
TYPE	EFF.
POLE	FRAME SIZE
HP	IP
kW	V
Hz	3 Ph
RPM	A
INS. H Δ t K	W2 U2 V2
AMB 40° C SF 1.2	U1 V1 W1
AMB 60° C SF 1.0	IEC / AS60034
DUTY SI MCR	BRG.
SER. NO.	WT. Kg
TECO Elec. & Mach. Co., Ltd.	

TECO MAXe3 PREMIUM SEVERE DUTY HIGH EFFICIENCY MOTORS	
TYPE	EFF.
POLE	FRAME SIZE
HP	IP
kW	V
Hz	3 Ph
RPM	A
INS. F Δ t K	W2 U2 V2
AMB 40° C SF 1.15	U1 V1 W1
AMB 55° C SF 1.0	IEC / AS60034
DUTY SI MCR	BRG.
SER. NO.	WT. Kg
TECO Elec. & Mach. Co., Ltd.	

Rotor Assembly

As per the stator, the rotor core is made up of exceptional high grade, low-loss insulated cold-rolled electro-magnetic steel laminations for maximum efficiency and low core losses.

The rotor cage is pressure die-cast high conductivity aluminium with wafer blades and balance supports integrally cast onto the rotor endrings.

On some larger AFJE motors, the rotor is of a copper/copper alloy rotor bar construction. This rotor construction offers superior performance and reliability. TECO utilizes high-frequency induction brazing as a means to enhance the structural integrity of the rotor bar to endring joint. Induction brazing provides an "all at once" uniform braze that reduces stresses and hot spots in the joint, which can cause premature fatigue and rotor bar failure.

The rotor is a press fit onto the high tensile steel shaft (ANSI10405) and is also keyed onto the shaft on motor frames D200 and larger.

Terminal Box

On foot and foot / flange mounted motors up-to and including D315M, the terminal box is mounted on the right-hand side viewed from drive-end and can be transferred to the left-hand side upon request.

For frames D315A (AFJE) and larger the terminal box is at the 2 o'clock position on the right hand side (alternative terminal box locations are available on request, please refer to TECO).

All terminal boxes have one-piece neoprene gaskets between frame, box and gland plate and can be rotated through 360° in 90° increments. An internal earth is provided within the motor terminal box.

TECO motors are shipped with a rubber gasket in the cable entry of the terminal box to prevent contamination during transport and storage. For installation, please remove the gasket and install a proper cable gland. Please refer to the dimensional tables within this catalogue for the correct gland size for your corresponding motor.

Motor Terminal Stud Tightening Torques in Nm

Frame Size	Stud Size	Tightening Torque (Nm)
D63-D71	M4	0.97
D80-D112	M5	1.9
D132-D180	M6	3.2
D200-D250	M8	7.8
D250-D315M	M10	15.1
D250-D315M	M12	26.5
D250-D355	M16	64.7

Note: Recommended Terminal Tightening Torques

Maximum Cable Sizes

Frame Size	Maximum Cable Size
D80 ~ D112	10 mm ²
D132 ~ D180	50 mm ²
D200 ~ D225	95 mm ²
D250 ~ D315M*	185 mm ²

Notes: Sizes based on -

3 core + Earth Copper PVC Insulated / PVC Sheathed or
 3 core + Earth Copper PVC Insulated / Steel Wire Armoured.
 Standard Cast Iron terminal box *
 Larger terminal boxes are available, please refer to TECO.

Frame sizes D315A-355, Type AFJE.

These units have an oversized fabricated steel terminal box and include an undrilled brass gland plate in order to prevent eddy currents produced by the use of single core supply cables which can present this problem when terminated via a ferrous gland plate. These gland plates are designed to be drilled (and tapped where applicable) by the customer to suit the incoming supply cables and glands being used. All terminal boxes are internally prime painted to prevent corrosion and include an internal earth terminal with lug for connection of the incoming earth conductor.

TECO are renowned for provide one of the largest terminal boxes on the market.

This ensures that there is more than enough space for terminating incoming cables, even in extra long cable runs or aluminium cables.



MAXe3 Mining Terminal Box

TERMINAL BOXES Motor frame sizes D315A-355, type AFJE (cont).

MAXe3 PREMIUM SEVERE DUTY

Terminal arrangement fitted to these motors is the TECO Heavy Duty Isolator type (x 6) and is complete with the necessary links for Star or Delta connection. Terminals are offset, top to bottom, to allow for 2 (or more) incoming supply cables per phase.

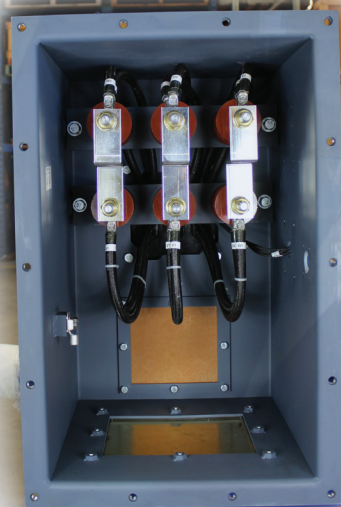

MAXe3 Premium Severe Terminal Box

MAXe3 MINING

Terminal arrangement fitted to these motors are the Weidmuller WFF300AH (x 6) rated for a voltage and current of up to 1100 Volts, 452 Amps.

These terminals are rated for Ex e Increased Safety use as standard and are IECEx certified, ensuring cool operating temperatures.

They incorporate phase barriers, non-twist locking terminals and have an insulation cover over each terminal as standard for added safety. Terminals are marked according to AS60034-8 and they are provided with Star and Delta links, for winding configuration and cable connection as required.

Options

Some available options in this range are as follows:

- 1000V motors
- Airstream rated IC418
- Anti-condensation heaters
- Auxiliary terminal boxes for Thermistor / Heater / RTD terminations
- Electromechanical "fail safe" Brake Motors
- Ex e, Increased Safety, IECEx certified
- Ex nA, Non-sparking, IECEx certified
- Ex tD, Dust Ignition Proof, IECEx certified
- Cooling Tower application
- Crane rated motors
- Double / non standard shaft extensions
- Encoder / Tacho
- Forced Cooling IC416
- Induction Generators
- Insulated bearing
- Multi-speed motors
- Rain covers for vertical shaft down motors
- Resistance temperature detectors (RTDs) winding and / or bearings
- Rotor Groundary brush / Earthing ring
- Dust covers to clear foreign debris
- Extended/Flying leads
- Special paint systems / colours
- SPM vibration studs
- Vibration sensor
- Stainless steel fasteners
- Thermistor protection (on motor frames <D160)
- Others on request.

Typical Performance Data **MAXe3**

TECO Cast-Iron TEFC 3-Phase Squirrel-Cage Induction Motors

AEMB High Efficiency Range 63 to 315M Frame (415V 50Hz)

Output kW	Full Load Rpm	Frame No.	Efficiency			Power Factor			Current		Torque					Inertia		Noise dB(A)	Weight Foot Mount Kgs (approx)
			Full Load (%)	3/4 Load (%)	1/2 Load (%)	Full Load (%)	3/4 Load (%)	1/2 Load (%)	Full Load (A)	Locked Rotor (%)	Full Load N-m	Locked Rotor %FLT	Locked Rotor t(secs) (hot)	Pull Up %FLT	Break-Down %FLT	ROTOR J = GD ² /4 Kg-m ²	MAX J = GD ² /4 Kg-m ²		
0.18	2740	63	61.0	59.5	55.0	77.5	69.0	57.0	0.55	455	0.63	363	7	363	363	0.0005	0.022	52	9
	1350	63	63.5	63.0	58.0	70.0	61.0	49.0	0.58	431	1.27	264	8.5	253	286	0.0008	0.103	48	11
	910	71	61.0	57.0	50.0	64.0	55.0	44.0	0.66	379	1.89	286	17.6	264	308	0.0018	0.175	45	12
	705	80	52.0	48.0	39.0	47.0	41.0	34.0	1.06	302	2.44	396	22	385	407	0.0025	0.543	44	16
0.37	2800	71	75.0	74.0	70.0	85.0	78.0	64.0	0.81	593	1.26	352	6.2	297	341	0.0008	0.043	54	12
	1405	71	74.5	73.0	68.5	69.5	60.5	48.0	1.00	530	2.51	358	7.1	297	336	0.0013	0.198	50	13
	920	80	72.5	72.0	68.5	72.0	62.5	49.0	0.99	535	3.84	253	11	236.5	264	0.0025	0.338	49	18
	710	90S	70.5	68.0	62.5	60.0	51.0	39.5	1.23	388	4.98	215	15.2	209	292	0.0045	1.04	49	22
0.55	2780	71	73.0	72.0	68.0	83.0	75.0	62.0	1.28	563	1.89	330	7	286	308	0.0008	0.062	53	16
	1405	80	71.5	70.5	65.0	74.0	65.0	52.0	1.47	524	3.74	286	9.6	253	308	0.0018	0.291	48	18
	910	80	68.0	68.0	63.0	72.0	62.0	49.0	1.59	365	5.77	253	11.5	231	253	0.0030	0.498	48	18
	690	90L	70.0	70.0	66.0	70.0	61.0	49.0	1.59	365	7.61	187	14.4	160	226	0.0058	1.54	47	27
0.75	2825	80	83.0	82.0	79.0	85.0	79.0	65.0	1.48	878	2.53	308	13	275	385	0.0015	0.081	56	20
	1440	80	84.5	82.0	79.0	74.5	65.0	50.5	1.66	783	4.97	325	21	286	413	0.0033	0.353	47	20
	935	90S	80.5	80.0	78.5	73.0	64.5	51.5	1.78	562	7.64	220	50	171	259	0.0055	0.913	45	24
	700	100L	76.6	76.5	73.0	60.0	50.5	38.5	2.27	441	10.2	259	55	242	253	0.0105	1.89	49	39
1.1	2815	80	84.5	84.0	82.0	85.0	79.0	66.0	2.13	845	3.72	330	11	286	363	0.0018	0.110	55	20
	1435	90S	86.0	86.5	85.5	80.5	73.5	60.5	2.21	814	7.31	281	34	198	319	0.0048	0.523	46	24
	935	90L	82.5	81.5	79.5	73.0	65.0	52.0	2.54	591	11.2	220	38	193	264	0.0068	1.40	45	29
	695	100L	79.5	80.0	77.5	64.0	55.0	42.5	3.01	498	15.1	231	48	220	237	0.0148	2.74	49	39
1.5	2895	90S	86.5	87.0	85.0	85.0	79.0	66.5	2.84	880	4.94	330	9	292	413	0.0030	0.145	56	24
	1440	90L	87.0	86.0	84.0	76.0	67.0	53.0	3.16	791	9.94	314	22	237	374	0.0063	0.670	47	29
	950	100L	84.0	84.0	81.5	73.0	67.0	54.0	3.40	735	15.1	259	38	248	308	0.0148	1.83	47	39
	705	112M	82.1	81.0	78.5	66.5	58.0	45.0	3.82	523	20.3	187	46	171	259	0.0225	3.65	49	50
2.2	2900	90L	87.5	87.0	85.0	80.0	72.0	58.0	4.37	892	7.23	374	8	325	446	0.0035	0.213	55	29
	1455	100L	88.5	88.0	86.0	81.0	73.0	59.0	4.27	913	14.4	303	20	215	391	0.0115	1.04	48	39
	965	112M	87.2	85.5	85.0	67.0	54.0	47.5	5.24	668	21.7	220	39	198	314	0.0210	2.68	48	50
	705	132S	84.6	83.5	82.0	69.0	60.0	46.5	5.24	572	29.8	253	32	226	292	0.0345	5.29	49	75
3	2870	100L	88.5	88.5	87.0	88.0	85.0	76.0	5.36	932	9.97	391	8	363	413	0.0063	0.280	59	39
	1450	100L	89.5	87.5	85.5	78.0	69.0	54.5	5.98	903	19.7	314	27	220	396	0.0130	1.34	48	39
	970	132S	88.8	87.5	86.0	78.0	71.0	59.0	6.03	746	29.5	220	40	198	325	0.0385	3.50	48	75
	715	132M	85.3	85.0	83.0	64.0	54.5	41.0	7.65	588	40.0	308	48	286	363	0.0450	6.97	50	82
4	2885	112M	90.3	90.5	90.0	90.0	87.0	80.0	6.85	949	13.2	347	9	330	385	0.0115	0.383	59	50
	1450	112M	90.0	89.5	89.0	82.0	76.0	63.5	7.54	862	26.3	303	16	171	363	0.0208	1.81	50	50
	970	132M	89.6	89.0	87.0	78.0	71.5	59.0	7.96	754	39.3	231	38	215	341	0.0515	4.75	52	82
	720	160M	87.1	86.0	84.5	70.5	62.0	48.5	9.06	607	53.0	209	39	187	275	0.0860	9.51	51	133
5.5	2930	132S	91.7	91.5	90.5	85.0	82.0	73.0	9.82	866	17.9	242	13	209	330	0.0190	0.505	65	75
	1460	132S	91.0	90.5	90.5	85.5	81.0	72.0	9.83	916	35.9	275	19	226	352	0.0333	2.37	54	75
	970	132M	89.5	89.5	88.5	74.5	66.5	54.0	11.5	826	54.1	270	20	237	369	0.0543	6.33	52	82
	720	160M	88.0	87.0	85.0	71.5	63.0	50.0	12.2	615	72.8	220	24	204	303	0.1260	12.7	54	133
7.5	2920	132S	91.7	91.0	91.5	85.0	79.0	70.0	13.4	821	24.5	231	10	193	303	0.0205	0.670	65	75
	1465	132M	91.7	92.0	91.5	85.0	80.5	71.0	13.4	896	48.8	281	14	215	380	0.0433	3.10	54	82
	970	160M	91.0	90.5	89.5	79.0	73.0	61.5	14.5	690	73.7	297	21	259	297	0.1210	8.34	52	133
	720	160L	89.0	88.0	86.0	71.0	64.5	51.0	16.5	606	99.4	248	24	237	325	0.1680	16.6	55	158
11	2945	160M	93.2	92.5	92.0	91.0	89.0	83.5	18.0	777	35.6	253	16	204	314	0.0458	0.973	67	133
	1465	160M	92.9	92.5	92.0	86.0	82.5	73.5	19.2	729	71.6	259	17	209	303	0.0918	4.57	57	133
	965	160L	91.5	91.0	90.5	80.0	74.5	63.0	20.9	766	109	314	14	281	325	0.1575	12.2	56	158
	720	180L	90.5	90.5	90.0	72.0	61.0	52.5	20.6	606	146	187	27	165	231	0.3195	24.3	56	210

- Notes:**
- All figures are based on tests carried out on 415 Volt 3 Phase Motors.
 - Test Method : IEC60034-2-1 Method
 - Tolerance : Page 33
 - dB(A): Mean Sound Pressure Level on no load and 1 metre on mains 50Hz sinusoidal supply, subject to 3dB(A) tolerance.
 - Motor data 8 pole and slower speeds not listed available on request.
 - Data subject to change without notice.

Other 50Hz Mains Voltage	380V	400V	440V	525V	550V	690V
Full Load Current multiplication factor (x)	1.092	1.038	0.943	0.790	0.755	0.601

Note: Figures for 525, 550, and 1000V are for comparative purposes only. 415V plated motors are not suitable for connection to these voltages.

Typical Performance Data **MAXe3**

TECO Cast-Iron TEFC 3-Phase Squirrel-Cage Induction Motors

AEMB High Efficiency Range 63 to 315M Frame (415V 50Hz)

Output kW	Full Load Rpm	Frame No.	Efficiency			Power Factor			Current			Torque					Inertia		dB(A)	Weight Foot Mount Kgs (approx)
			Full Load (%)	3/4 Load (%)	1/2 Load (%)	Full Load (%)	3/4 Load (%)	1/2 Load (%)	Full Load (A)	Locked Rotor (%)	Full Load N-m	Locked Rotor %FLT	Locked Rotor t(secs) (hot)	Pull Up %FLT	Break-Down %FLT	ROTOR J = GD ² /4 Kg-m ²	MAX J = GD ² /4 Kg-m ²			
15	2935	160M	93.5	92.0	91.5	90.0	87.0	80.0	24.8	786	48.7	264	12	237	341	0.0513	1.28	67	133	
	1465	160L	93.0	93.0	92.5	86.0	83.0	74.5	26.1	747	97.6	270	12	215	314	0.1155	6.02	57	158	
	970	180LC	92.0	92.0	92.0	84.0	81.0	72.5	27.0	630	147	253	19	182	275	0.3355	15.9	56	205	
	730	200LC	91.7	90.5	89.0	78.0	72.0	60.0	29.2	616	196	215	20	187	253	0.5213	31.8	57	282	
18.5	2940	160L	93.8	93.5	93.0	90.5	87.0	79.5	30.3	809	60.0	286	10	248	330	0.0593	1.55	67	158	
	1480	180M	94.0	94.0	93.0	83.0	76.0	64.5	33.0	742	119	220	13	154	275	0.1768	7.42	62	190	
	975	200LC	93.0	93.0	92.5	82.0	78.5	69.5	33.7	653	181	253	22	182	270	0.4588	19.7	56	295	
	735	225SC	93.6	93.0	92.5	77.0	71.5	60.0	35.7	532	240	215	32	138	215	0.7268	39.3	58	360	
22	2950	180MA	94.1	94.0	93.0	87.0	85.0	77.0	37.4	882	71.1	248	12	198	303	0.0708	1.89	67	190	
	1480	180LC	94.5	94.0	93.5	83.0	76.5	65.0	39.0	692	142	220	14	154	264	0.1980	8.76	62	205	
	975	200LC	93.5	93.5	93.5	82.5	79.5	71.0	39.7	655	215	242	24	198	264	0.5213	23.4	56	295	
	740	225MC	93.7	93.0	92.0	73.0	66.0	54.0	44.7	515	284	248	32	160	253	0.8140	46.8	58	375	
30	2945	200LA	94.5	94.0	93.0	90.5	91.0	88.5	48.8	717	97.1	187	17	132	275	0.1505	2.43	74	300	
	1475	200LC	94.5	94.5	94.5	86.0	84.5	77.0	51.4	798	194	292	11	237	313	0.3628	11.5	62	295	
	985	225MC	94.6	94.0	93.5	83.0	79.5	70.0	53.1	574	290	231	29	187	253	0.7558	30.5	60	388	
	735	250SC	93.5	93.0	92.0	74.5	68.0	56.0	59.9	701	389	286	20	248	325	1.2345	61.3	65	510	
37	2960	200LA	94.9	94.5	93.5	91.0	90.5	87.0	59.6	780	119	215	15	154	303	0.1883	2.98	74	300	
	1480	225SC	95.4	95.0	94.5	85.0	82.0	74.0	63.5	724	239	226	17	204	319	0.4740	14.1	66	360	
	985	250SC	95.1	94.5	94.5	86.0	82.5	74.0	62.9	715	358	270	24	231	292	1.1400	37.8	63	510	
	740	250MC	94.0	93.0	92.0	76.0	70.0	58.5	72.1	680	477	270	20	237	297	1.4173	75.5	68	570	
45	2960	225MA	95.6	95.0	94.0	93.0	92.0	87.0	70.4	736	145	165	18	132	352	0.2968	3.53	79	377	
	1480	225MC	95.4	95.0	95.0	85.5	82.0	74.0	76.7	665	290	220	14	187	303	0.4948	16.7	66	388	
	985	250MC	94.5	94.5	94.0	86.5	84.0	76.0	76.6	764	436	264	20	226	297	1.2765	44.8	63	570	
55	2970	250SA	95.8	94.5	94.0	91.5	90.5	87.0	87.3	739	177	165	18	143	346	0.3868	4.32	74	480	
	1485	250SC	95.8	95.0	95.0	86.0	83.5	76.5	92.8	744	353	242	16	270	303	0.9778	20.3	70	510	
	984	280SC	95.7	95.0	94.3	84.0	81.5	74.0	95.0	684	533	182	22	154	253	2.1250	55.0	73*	750	
75	2960	250MA	95.5	95.0	95.0	92.0	91.0	88.0	119.0	693	242	154	14	143	325	0.4540	5.60	79*	540	
	1480	250MC	95.7	95.0	95.0	86.0	84.5	79.0	127.0	740	484	242	14	253	275	1.1225	26.8	70*	570	
	984	280MC	95.8	95.7	95.3	85.0	82.0	75.0	128.0	684	727	176	27	150	253	2.7750	46.8	73*	850	
90	2960	280SA	96.1	95.7	94.8	90.0	88.0	82.0	145.0	755	290	143	11	121	253	0.6750	6.88	80*	660	
	1480	280SC	96.2	95.5	94.9	86.5	83.6	77.0	148.0	740	580	176	13	150	253	1.8250	33.0	75*	820	
	985	315SC	96.4	95.8	95.2	85.5	82.5	76.0	152.0	720	872	171	31	144	253	4.2750	88.3	73*	980	
110	2960	280MA	96.3	95.7	94.7	90.0	88.0	82.0	177.0	763	355	132	11	112	253	0.8000	8.08	80*	720	
	1482	280MC	96.4	96.3	95.9	87.5	84.0	77.5	181.0	746	709	154	13	121	253	2.1500	39.0	75*	880	
	985	315MC	96.5	96.0	95.3	86.0	83.0	76.5	184.0	734	1068	110	26	99	242	4.9750	105	73*	1070	
132	2976	315SA	96.6	95.7	94.9	90.0	88.0	82.0	211.0	754	423	127	28	108	242	1.2750	9.13	82*	900	
	1482	315SC	96.7	95.9	95.3	88.0	84.5	78.5	216.0	736	850	154	27	121	242	3.0500	44.0	75*	1000	
	986	315MC	96.5	96.0	95.4	86.0	83.0	76.5	221.0	719	1274	110	18	99	242	5.1750	120	73*	1180	
150	2976	315MA	96.7	96.1	95.3	90.0	89.0	83.0	240.0	750	481	116	27	100	242	1.4500	10.5	82*	940	
	1485	315MC	96.9	96.0	95.7	88.0	84.5	79.0	245.0	735	964	110	26	99	242	3.5500	50.5	75*	1080	
185	2982	315MA	97.0	96.3	95.6	90.0	89.0	83.0	295.0	780	592	116	25	100	242	1.5000	12.8	82*	1050	
	1486	315MC	97.0	96.0	95.7	88.5	85.0	79.5	300.0	767	1186	110	19	99	242	3.6000	61.8	75*	1150	

- Notes:**
- All figures are based on tests carried out on 415 Volt 3 Phase Motors.
 - Test Method : IEC60034-2-1 Method
 - Tolerance : Page 33
 - Mean Sound Pressure Level on no load and 1 metre on mains 50Hz sinusoidal supply, subject to 3dB(A) tolerance.
 - Motor data 8 pole and slower speeds not listed available on request.
 - 185kW motor in D315MC frame with fabricated steel terminal box.
 - Data subject to change without notice.
 - *Low noise option available D280-315M.
 - Larger sizes, please refer to TECO.

Other 50Hz Mains Voltage	380V	400V	440V	525V	550V	690V
Full Load Current multiplication factor (x)	1.092	1.038	0.943	0.790	0.755	0.601

Note: Figures for 525, 550, and 1000V are for comparative purposes only. 415V plated motors are not suitable for connection to these voltages.

Outline Dimensions Sheet **MAXe3**

TECO Cast-Iron TEFC 3-Phase Squirrel-Cage Induction Motors Frame 63 - 132 Foot Mount

Totally-Enclosed Fan-Cooled Squirrel-Cage Rotor

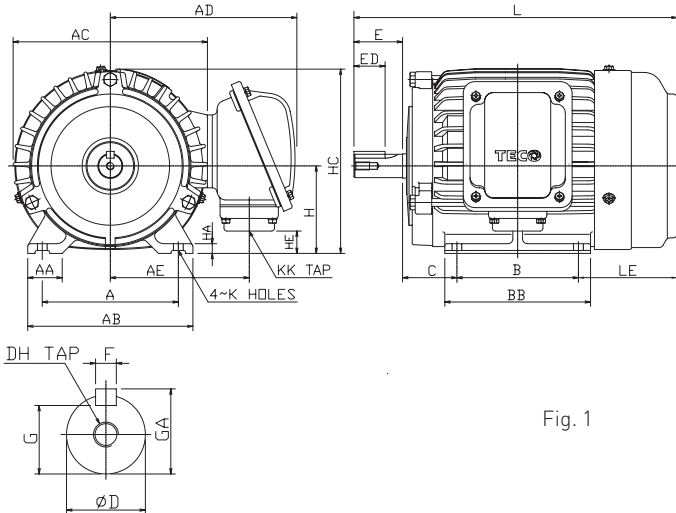

Fig. 1

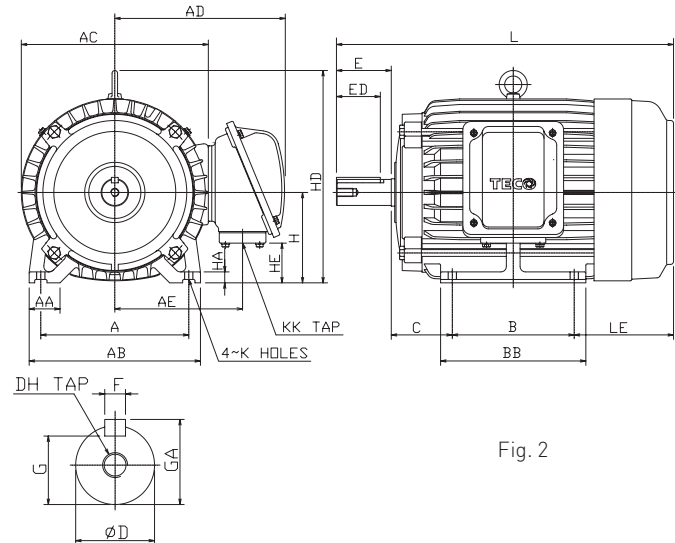

Fig. 2

Output (kW)				Frame Size	Fig. No.	Dimensions (mm)												
2P	4P	6P	8P			A	AA	AB	AC	AD	AE	B	BB	C	H	HA	HC	HD
0.18	0.18	-	-	63	1	100	28	120	144	138	100	80	100	40	63	8	135	-
0.37 / 0.55	0.37	0.18	-	71		112	35.5	140	162	148	110	90	115	45	71	8	152	-
0.75 / 1.1	0.55 / 0.75	0.37 / 0.55	0.18	80		125	35.5	155	177	179	130	100	130	50	80	9	168	-
1.5	1.1	0.75	0.37	90S		140	35.5	170	200	192	143	100	130	56	90	10	190	-
2.2	1.5	1.1	0.55	90L		140	35.5	170	200	192	143	125	150	56	90	10	190	-
3	2.2 / 3	1.5	0.75 / 1.1	100L		160	45	195	219	202	153	140	175	63	100	12.5	-	243
4	4	2.2	1.5	112M		190	45	224	238	211	162	140	175	70	112	14	-	265
5.5 / 7.5	5.5	3	2.2	132S		216	45	250	273	249	187	140	175	89	132	16	-	310
-	7.5	4 / 5.5	3	132M		216	45	250	273	249	187	178	212	89	132	16	-	310

Frame Size	Shaft Extension					Bearings								
	HE	K	KK	L	LE	D	E	ED	F	G	GA	DH	DE	NDE
63	10	7	M20xP1.5	219	76	11	23	18	4	8.5	12.5	M4x8	6201ZZC3	6201ZZC3
71	35	7	M20xP1.5	250.5	85.5	14	30	24	5	11	16	M5x10	6202ZZC3	6202ZZC3
80	13	10	M25xP1.5	282.5	92.5	19	40	25	6	15.5	21.5	M6x12	6204ZZC3	6204ZZC3
90S	23	10	M25xP1.5	307.5	101.5	24	50	32	8	20	27	M8x16	6205ZZC3	6205ZZC3
90L	23	10	M25xP1.5	332.5	101.5	24	50	32	8	20	27	M8x16	6205ZZC3	6205ZZC3
100L	33	12	M25xP1.5	374.5	111.5	28	60	40	8	24	31	M10x20	6206ZZC3	6205ZZC3*
112M	45	12	M25xP1.5	391.5	121.5	28	60	40	8	24	31	M10x20	6306ZZC3	6206ZZC3**
132S	58	12	M40xP1.5	454	145	38	80	64	10	33	41	M12x24	6308ZZC3	6306ZZC3
132M	58	12	M40xP1.5	492	145	38	80	64	10	33	41	M12x24	6308ZZC3	6306ZZC3

- Notes:**
1. Tolerance: Refer to page 33.
 2. Data subject to change without notice and should not be used for installation purposes.
 3. *Before June 2022, NDE bearing was 6305.
 4. **Before June 2022, NDE bearing was 6306.



**MAXe3 Premium Severe Duty
Frame D250**

Outline Dimensions Sheet **MAXe3**

TECO Cast-Iron TEFC 3-Phase Squirrel-Cage Induction Motors Frame 160 - 250 Foot Mount

Totally-Enclosed Fan-Cooled Squirrel-Cage Rotor

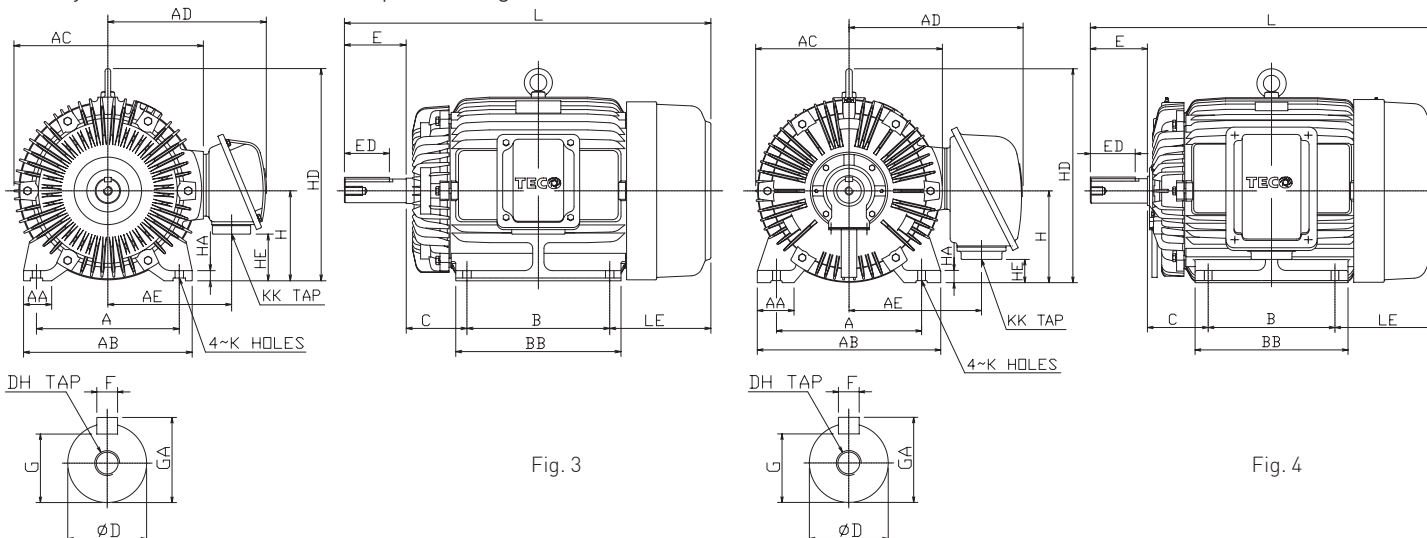

Fig. 3

Fig. 4

Output (kW)				Frame Size	Fig. No.	Dimensions (mm)											
2P	4P	6P	8P			A	AA	AB	AC	AD	AE	B	BB	C	H	HA	HD
-	11	7.5	4 / 5.5	160M	3	254	50	300	334	287	225	210	250	108	160	18	377
18.5	15	11	7.5	160L		254	50	300	334	287	225	254	300	108	160	18	377
22	-	-	-	180MA	4	279	75	355	382	312	250	241	297	121	180	20	431
-	18.5	-	-	180MC		279	75	355	382	312	250	241	297	121	180	20	431
-	22	15	11	180LC	3	279	75	355	382	312	250	279	335	121	180	20	431
30 / 37	-	-	-	200LA		318	80	400	420	374	287	305	365	133	200	25	469
-	30	18.5 / 22	15	200LC	4	318	80	400	420	374	287	305	365	133	200	25	469
-	37	-	18.5	225SC		356	90	450	458	427	330	286	350	149	225	30	524
45	-	-	-	225MA	4	356	90	450	458	427	330	311	375	149	225	30	524
-	45	30	22	225MC		356	90	450	458	427	330	311	375	149	225	30	524
55	-	-	-	250SA	4	406	100	500	510	493	375	311	385	168	250	36	595
-	55	37	30	250SC		406	100	500	510	493	375	311	385	168	250	36	595
75	-	-	-	250MA	4	406	100	500	510	493	375	349	425	168	250	36	595
-	75	45	37	250MC		406	100	500	510	493	375	349	425	168	250	36	595

Frame Size	Shaft Extension					Bearings								
	HE	K	KK	L	LE	D	E	ED	F	G	GA	DH	DE	NDE
160M	83	14.5	M40 × P1.5	608	180	42	110	80	12	37	45	M16 × 32	6309ZZC3	6307ZZC3
160L	83	14.5	M40 × P1.5	652	180	42	110	80	12	37	45	M16 × 32	6309ZZC3	6307ZZC3
180MA	103	14.5	M40 × P1.5	672	200	48	110	80	14	42.5	51.5	M16 × 32	{6211C3}	{6211C3}
180MC	103	14.5	M40 × P1.5	672	200	48	110	80	14	42.5	51.5	M16 × 32	6311ZZC3	6310ZZC3
180LC	103	14.5	M40 × P1.5	710	200	48	110	80	14	42.5	51.5	M16 × 32	6311ZZC3	6310ZZC3
200LA	88	18.5	M50 × P1.5	770	222	55	110	80	16	49	59	M20 × 40	{6312C3}	{6212C3}
200LC	88	18.5	M50 × P1.5	770	222	55	110	80	16	49	59	M20 × 40	6312C3	6212C3
225SC	57	18.5	M50 × P1.5	816	241	60	140	110	18	53	64	M20 × 40	6313C3	6213C3
225MA	57	18.5	M50 × P1.5	811	241	55	110	80	16	49	59	M20 × 40	{6312C3}	{6212C3}
225MC	57	18.5	M50 × P1.5	841	241	60	140	110	18	53	64	M20 × 40	6313C3	6213C3
250SA	42	24	M63 × P1.5	882.5	263.5	60	140	110	18	53	64	M20 × 40	{6313C3}	{6213C3} {6313C3*}
250SC	42	24	M63 × P1.5	882.5	263.5	70	140	110	20	62.5	74.5	M20 × 40	NU316C3	6313C3
250MA	42	24	M63 × P1.5	920.5	263.5	60	140	110	18	53	64	M20 × 40	{6313C3}	{6213C3} {6313C3*}
250MC	42	24	M63 × P1.5	920.5	263.5	70	140	110	20	62.5	74.5	M20 × 40	NU316C3	6313C3

- Notes:**
1. Tolerance: Refer to page 33
 2. * 6313C3 from July 2016 manufacture
 3. Data subject to change without notice and should not be used for installation purposes.

Outline Dimensions Sheet **MAXe3**

TECO Cast-Iron TEFC 3-Phase Squirrel-Cage Induction Motors

Frame 280 - 315M Foot Mount

Totally-Enclosed Fan-Cooled Squirrel-Cage Rotor

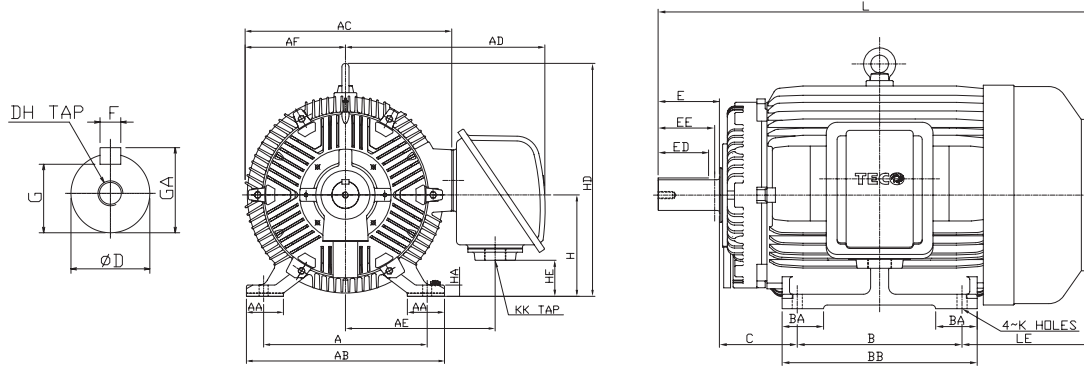

Output (kW)				Frame Size	Dimensions (mm)													
2P	4P	6P	8P		A	AA	AB	AC	AD	AE	AF	B	BA	BB	C	H	HA	
90	-	-	-	280SA	457	110	560	603	600	445	293	368	110	445	190	280	30	
-	90	55	45	280SC	457	110	560	603	600	445	293	368	110	445	190	280	30	
110	-	-	-	280MA	457	110	560	603	600	445	293	419	130	495	190	280	30	
-	110	75	55	280MC	457	110	560	603	600	445	293	419	130	495	190	280	30	
132	-	-	-	315SA	508	115	615	642	620	465	312	406	115	490	216	315	35	
-	132	90	75	315SC	508	115	615	642	620	465	312	406	115	490	216	315	35	
150 / 185	-	-	-	315MA	508	115	615	642	620	465	312	457	115	540	216	315	35	
-	150	110 / 132	90	315MC	508	115	615	642	620	465	312	457	115	540	216	315	35	
-	185	-	-	315MB	508	115	615	642	620	465	312	457	115	540	216	315	35	
-	185	-	-	315MC**	508	115	615	642	703	482	312	457	115	540	216	315	35	

Frame Size	Shaft Extension						Bearings									
	HD	HE	K	KK	L	LE	D	E	ED	EE	F	G	GA	DH	DE	NDE
280SA	651	82	24	M63x1.5	1042	344	65	140	110	134	18	58	69	M20x30	6314C3	6314C3
280SC	651	82	24	M63x1.5	1072	344	80	170	140	157	22	71	85	M20x30	NU318C3	6316C3
280MA	651	82	24	M63x1.5	1092	343	65	140	110	134	18	58	69	M20x30	6314C3	6314C3
280MC	651	82	24	M63x1.5	1122	343	80	170	140	157	22	71	85	M20x30	NU318C3	6316C3
315SA	723	112	28	M63x1.5	1131	369	65	140	110	134	18	58	69	M20x30	6314C3	6314C3
315SC	723	112	28	M63x1.5	1161	369	85	170	140	157	22	76	90	M20x30	NU320C3	6316C3
315MA	723	112	28	M63x1.5	1182	369	65	140	110	134	18	58	69	M20x30	6314C3	6314C3
315MC	723	112	28	M63x1.5	1212	369	85	170	140	157	22	76	90	M20x30	NU320C3	6316C3
315MB	723	112	28	M63x1.5	1212	369	85	170	140	157	22	76	90	M20x30	NU320C3	6316C3
315MC**	723	112	28	BLANK	1212	369	95	170	140	157	25	86	100	M24x48	NU320C3	6316C3

- Notes:**
1. Tolerance: Refer to page 33
 2. Usable Shaft Length : EE
 3. ** 185kW motor in D315MC frame with fabricated steel terminal box and oversize DE shaft.
 4. Data subject to change without notice and should not be used for installation purposes.

**MAXe3 Premium Severe Duty
Frame D280**

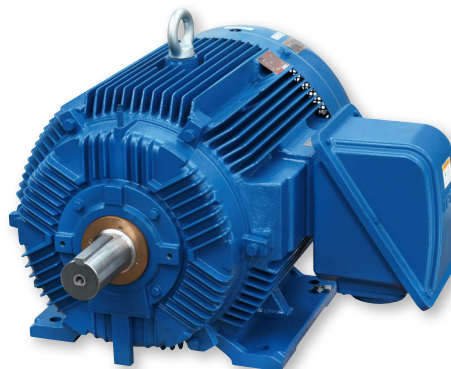

Outline Dimensions Sheet **MAXe3**

TECO Cast-Iron TEFC 3-Phase Squirrel-Cage Induction Motors Frame 315A - 355 Foot Mount AFJE

Totally-Enclosed Fan-Cooled Squirrel-Cage Rotor

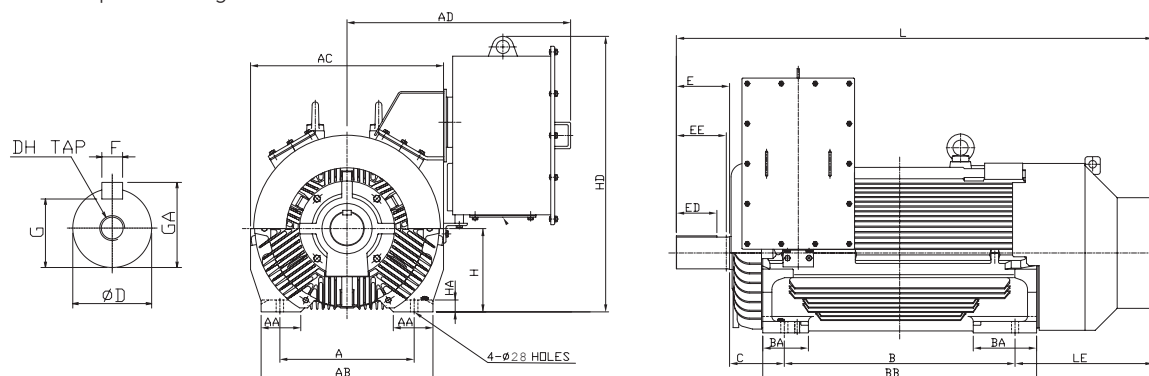

Output (kW)		Frame Size	Dimensions (mm)												
4P	6P		A	AA	AB	AC	AD*	B	BA	BB	C	H	HA	HD*	
-	150 / 185	315A	508	150	650	730	846	560	180	730	216	315	45	992	
220 / 250 / 300	220	315C	508	150	650	730	846	710	180	880	216	315	45	992	
375	260 / 315	315D	508	150	650	730	846	910	180	1080	216	315	45	1042	
450	-	355C	610	150	750	810	959	900	210	1120	254	355	45	1227	

Output (kW)		Frame Size	Shaft Extension - Direct / Belt Drive#										Bearings	
4P	6P		L	LE	D	E	ED	EE	F	G	GA	DH	DE	NDE
-	150 / 185	315A	1491/1531	545	95/110	170/210	140/160	157/197	25/28	86/100	100/116	M24X48	6220C3 / NU324C3	6320C3
220 / 250	220	315C	1641/1681	545	95/110	170/210	140/160	157/197	25/28	86/100	100/116	M24X48	6220C3 / NU324C3	6320C3
300	-	315C	1641/1681	545	95/125	170/210	140/160	157/197	25/32	86/114	100/132	M24X48	6220C3 / NU326C3	6320C3
375	260 / 315	315D	1841/1881	545	95/125	170/210	140/160	157/197	25/32	86/114	100/132	M24X48	6220C3 / NU326C3	6320C3
450	-	355C	1894/1934	570	95/125	170/210	140/160	157/197	25/32	86/114	100/132	M24X48	6222C3 / NU326C3	6322C3

- Notes:**
1. Tolerance: Refer to page 33
 2. Usable Shaft Length: EE
 3. Fitted with undrilled blank gland plate.
 4. Data subject to change without notice and should not be used for installation purposes.
 5. AFJE performance data, please refer to TECO.
 6. *AD & *HD as per MAXe3 Premium Severe Duty
 7. # Belt Drive as standard

AFJE MAXe3 Mining Motor
FRAME SIZES D315A-355

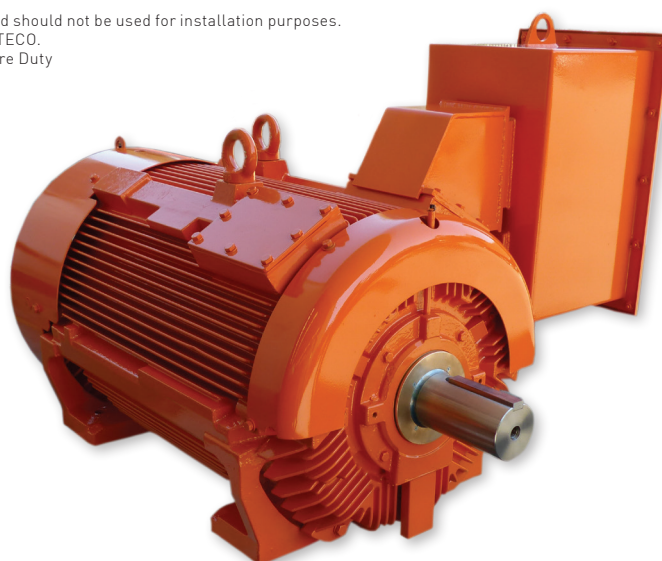

Outline Dimensions Sheet **MAXe3**

TECO Cast-Iron TEFC 3-Phase Squirrel-Cage Induction Motors

Frame 63 - 132 Flange Mount

Totally-Enclosed Fan-Cooled Squirrel-Cage Rotor

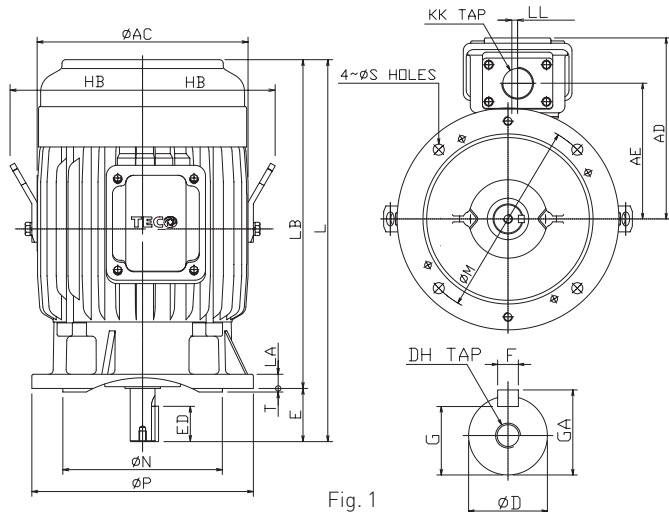

Fig. 1

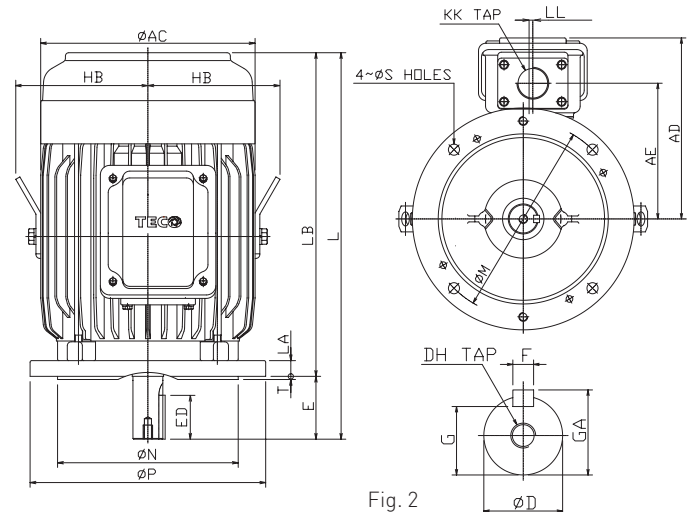

Fig. 2

Output (kW)				Frame Size	Fig No.	Dimensions (mm)										Flange		
2P	4P	6P	8P			AC	AD	AE	HB	KK	L	LA	LB	LL	M	N	P	
0.18	0.18	-	-	63	1	144	123	93	-	M20XP1.5	248	12	225	0	115	95	140	
0.37 / 0.55	0.37	0.18	-	71		162	133	103	-	M20XP1.5	278	12	248	17	130	110	160	
0.75 / 1.1	0.55 / 0.75	0.37 / 0.55	0.18	80	2	177	179	130	-	M25XP1.5	282	12	242	15	165	130	200	
1.5	1.1	0.75	0.37	90S	1	200	192	143	-	M25XP1.5	347	12	297	15	165	130	200	
2.2	1.5	1.1	0.55	90L		200	192	143	-	M25XP1.5	372	12	322	15	165	130	200	
3	2.2 / 3	1.5	0.75 / 1.1	100L	2	219	202	153	140	M25XP1.5	375	16	315	15	215	180	250	
4	4	2.2	1.5	112M	1	235	211	162	150	M25XP1.5	431	16	371	15	215	180	250	
5.5 / 7.5	5.5	3	2.2	132S	2	273	249	187	169	M40XP1.5	454	20	374	13	265	230	300	
-	7.5	4 / 5.5	3	132M		273	249	187	169	M40XP1.5	492	20	412	13	265	230	300	

Frame Size	Flange		Shaft Extension							Bearings	
	S	T	D	E	ED	F	G	GA	DH	DE	NDE
63	10	3	11	23	18	4	8.5	12.5	M4×8	6201ZXC3	6201ZXC3
71	10	3.5	14	30	24	5	11	16	M5×10	6202ZXC3	6202ZXC3
80	12	3.5	19	40	25	6	15.5	21.5	M6×12	6204ZXC3	6204ZXC3
90S	12	3.5	24	50	32	8	20	27	M8×16	6205ZXC3	6205ZXC3
90L	12	3.5	24	50	32	8	20	27	M8×16	6205ZXC3	6205ZXC3
100L	14.5	4	28	60	40	8	24	31	M10×20	6206ZXC3	6205ZXC3*
112M	14.5	4	28	60	40	8	24	31	M10×20	6306ZXC3	6206ZXC3**
132S	14.5	4	38	80	64	10	33	41	M12×24	6308ZXC3	6306ZXC3
132M	14.5	4	38	80	64	10	33	41	M12×24	6308ZXC3	6306ZXC3

- Notes:**
1. Data subject to change without notice and should not be used for installation purposes.
 2. Tolerance: Refer to page 33.
 3. Lifting lugs not provided on frames D90 and smaller.
 4. *Before June 2022, NDE bearing was 6305.
 5. **Before June 2022, NDE bearing was 6306.

Outline Dimensions Sheet **MAXe3**

TECO Cast-Iron TEFC 3-Phase Squirrel-Cage Induction Motors Frame 160 - 250 Flange Mount

Totally-Enclosed Fan-Cooled Squirrel-Cage Rotor

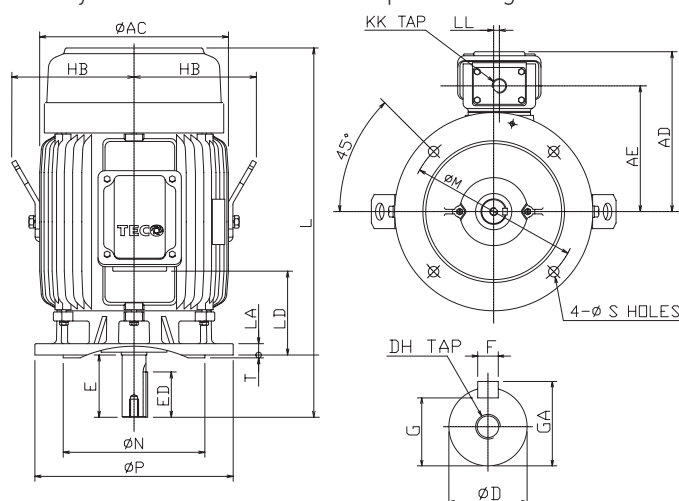

Fig. 3

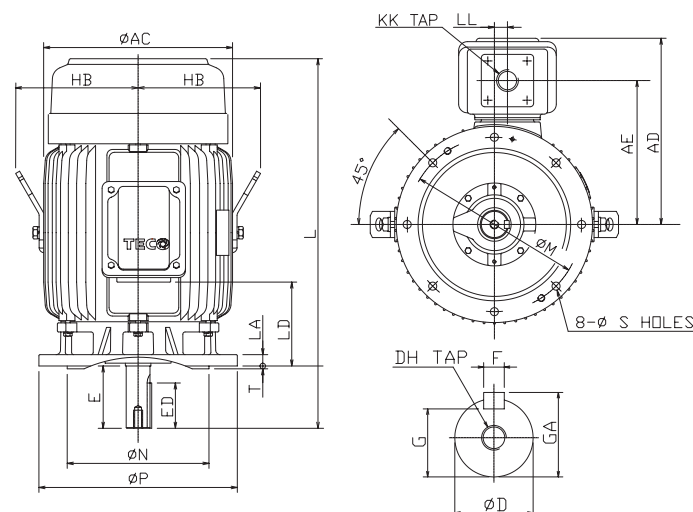

Fig. 4

Output (kW)				Frame Size	Fig. No.	Dimensions (mm)								Flange			
2P	4P	6P	8P			AC	AD	AE	HB	KK	L	LA	LD	LL	M	N	P
11 / 15	11	7.5	4 / 5.5	160M	3	334	287	225	217	M40 × P1.5	608	20	126	10	300	250	350
18.5	15	11	7.5	160L		334	287	225	217	M40 × P1.5	652	20	148	10	300	250	350
22				180MA		382	312	250	241	M40 × P1.5	672	20	155	10	300	250	350
	18.5			180MC		382	312	250	241	M40 × P1.5	672	20	155	10	300	250	350
	22	15	11	180LC		382	312	250	241	M40 × P1.5	710	20	174	10	300	250	350
30 / 37				200LA		420	374	287	260	M50 × P1.5	770	20	154	20	350	300	400
	30	18.5 / 22	15	200LC		420	374	287	260	M50 × P1.5	770	20	154	20	350	300	400
	37		18.5	225SC		458	427	330	286	M50 × P1.5	816	22	94	30	400	350	450
45				225MA		458	427	330	286	M50 × P1.5	811	22	107	30	400	350	450
	45	30	22	225MC		458	427	330	286	M50 × P1.5	841	22	107	30	400	350	450
55				250SA	4	510	493	375	312	M63 × P1.5	882.5	22	86	30	500	450	550
	55	37	30	250SC		510	493	375	312	M63 × P1.5	882.5	22	86	30	500	450	550
75				250MA		510	493	375	312	M63 × P1.5	920.5	22	105	30	500	450	550
	75	45	37	250MC		510	493	375	312	M63 × P1.5	920.5	22	105	30	500	450	550

Frame Size	Flange		Shaft Extension							Bearings	
	S	T	D	E	ED	F	G	GA	DH	DE	NDE
160M	18.5	5	42	110	80	12	37	45	M16 × 32	6309ZZ	6307ZZ
160L	18.5	5	42	110	80	12	37	45	M16 × 32	6309ZZ	6307ZZ
180MA	18.5	5	48	110	80	14	42.5	51.5	M16 × 32	6211C3	6211C3
180MC	18.5	5	48	110	80	14	42.5	51.5	M16 × 32	6311ZZ	6310ZZ
180LC	18.5	5	48	110	80	14	42.5	51.5	M16 × 32	6311ZZ	6310ZZ
200LA	18.5	5	55	110	80	16	49	59	M20 × 40	6312C3	6212C3
200LC	18.5	5	55	110	80	16	49	59	M20 × 40	6312	6212
225SC	18.5	5	60	140	110	18	53	64	M20 × 40	6313	6213
225MA	18.5	5	55	110	80	16	49	59	M20 × 40	6312C3	6212C3
225MC	18.5	5	60	140	110	18	53	64	M20 × 40	6313	6213
250SA	18.5	5	60	140	110	18	53	64	M20 × 40	6313C3	6213C3
250SC	18.5	5	70	140	110	20	62.5	74.5	M20 × 40	6313C3	6313
250MA	18.5	5	60	140	110	18	53	64	M20 × 40	6313C3	6213C3
250MC	18.5	5	70	140	110	20	62.5	74.5	M20 × 40	6313C3	6313

- Notes:
1. Tolerance: Refer to page 33
 2. * 6313C3 from July 2016 manufacture
 3. Data subject to change without notice and should not be used for installation purposes.

Outline Dimensions Sheet **MAXe3**

TECO Cast-Iron TEFC 3-Phase Squirrel-Cage Induction Motors

Frame 63 - 200 Foot and Flange Mount

Totally-Enclosed Fan-Cooled Squirrel-Cage Rotor

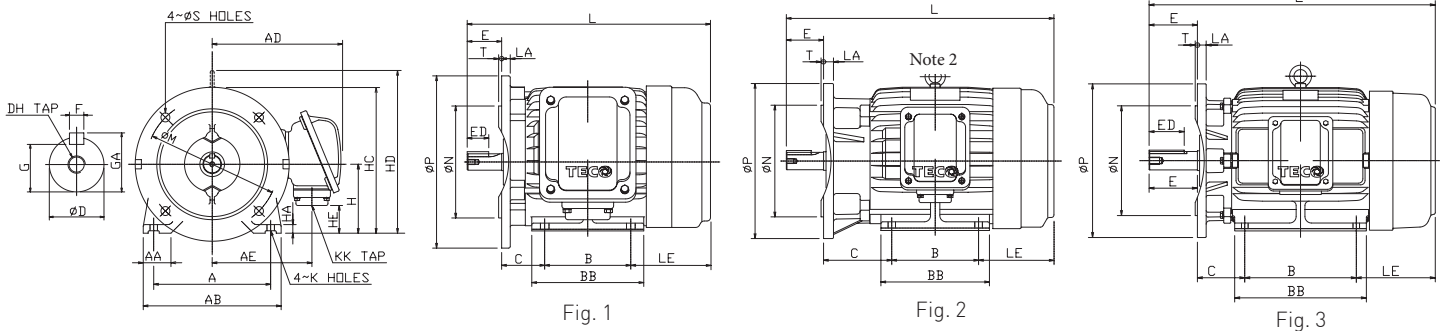

Output (kW)				Frame Size	Fig. No.	Dimensions (mm)														
2P	4P	6P	8P			A	AA	AB	AD	AE	B	BB	C	H	HA	HC	HD	HE	K	KK
0.18	0.18	-	-	63	2	100	28	120	123	97	80	100	69	63	8	135	-	10	7	M20 X P1.5
0.37 / 0.55	0.37	0.18	-	71		112	35.5	140	133	107	90	115	72	71	8	152	-	35	7	M20 X P1.5
0.75 / 1.1	0.55 / 0.75	0.37 / 0.55	0.18	80	1	125	35.5	155	159	129	100	130	50	80	9	180	-	13	10	M25 X P1.5
1.5	1.1	0.75	0.37	90S	2	140	35.5	170	170	140	100	130	95	90	10	190	-	23	10	M25 X P1.5
2.2	1.5	1.1	0.55	90L		140	35.5	170	170	140	125	150	95	90	10	190	-	23	10	M25 X P1.5
3	2.2 / 3	1.5	0.75 / 1.1	100L	2	160	45	195	180	150	140	175	103	100	12.5	-	243	33	12	M25 X P1.5
4	4	2.2	1.5	112M		190	45	224	189	159	140	175	110	112	14	-	265	45	12	M25 X P1.5
5.5 / 7.5	5.5	3	2.2	132S	2	216	45	250	225	184	140	175	139	132	16	-	310	58	12	M40 X P1.5
-	7.5	4 / 5.5	3	132M		216	45	250	225	184	178	212	139	132	16	-	310	58	12	M40 X P1.5
11 / 15	11	7.5	4 / 5.5	160M	3	254	50	300	263	222	210	250	108	160	18	-	377	83	14.5	M40 X P1.5
18.5	15	11	7.5	160L		254	50	300	263	222	254	300	108	160	18	-	377	83	14.5	M40 X P1.5
22	18.5	-	-	180MA	3	279	75	355	305	247	241	297	121	180	20	-	421	103	14.5	M40 X P1.5
-	22	15	11	180LC		279	75	355	305	247	279	335	121	180	20	-	421	103	14.5	M40 X P1.5
30 / 37	30	18.5 / 22	15	200LA	3	318	80	400	342	285	305	365	133	200	25	-	469	88	18.5	M50 X P1.5
30 / 37	30	18.5 / 22	15	200LC		318	80	400	342	285	305	365	133	200	25	-	469	88	18.5	M50 X P1.5

Frame Size	Flange								Shaft Extension							Bearings	
	LA	LE	L	M	N	P	S	T	D	E	ED	F	G	GA	DH	DE	NDE
63	12	23	248	115	95	140	10	3	11	23	18	4	8.5	12.5	M4×6	6201ZC3	6201ZC3
71	12	40	277	130	110	160	10	3.5	14	30	24	5	11	16	M5×7.5	6202ZC3	6202ZC3
80	12	50	282	165	130	200	12	3.5	19	40	25	6	15.5	21.5	M6×9	6204ZC3	6204ZC3
90S	16	50	346	165	130	200	12	3.5	24	50	32	8	20	27	M8×12	6205ZC3	6205ZC3
90L	16	50	371	165	130	200	12	3.5	24	50	32	8	20	27	M8×12	6205ZC3	6205ZC3
100L	20	60	374	215	180	250	15	4	28	60	40	8	24	31	M10×15	6206ZC3	6205ZC3*
112M	20	60	431	215	180	250	15	4	28	60	40	8	24	31	M10×15	6306ZC3	6206ZC3**
132S	20	80	454	265	230	300	15	4	38	80	64	10	33	41	M12×18	6308ZC3	6306ZC3
132M	20	80	492	265	230	300	15	4	38	80	64	10	33	41	M12×18	6308ZC3	6306ZC3
160M	20	110	608	300	250	350	19	5	42	110	80	12	37	45	M16×24	6309ZC3	6307ZC3
160L	20	110	652	300	250	350	19	5	42	110	80	12	37	45	M16×24	6309ZC3	6307ZC3
180MA	20	110	672	300	250	350	19	5	48	110	80	14	42.5	51.5	M16×24	{6211C3}	{6211C3}
180LC	20	110	710	300	250	350	19	5	48	110	80	14	42.5	51.5	M16×24	6311ZC3	6310ZC3
200LA	20	110	770	350	300	400	19	5	55	110	80	16	49	59	M20×30	{6312C3}	{6212C3}
200LC	20	110	770	350	300	400	19	5	55	110	80	16	49	59	M20×30	{6312C3}	{6212C3}

- Notes:**
1. Tolerance: Refer to page 33.
 2. Eyebolts not provided on frames D90 and smaller.
 3. *Before June 2022, NDE bearing was 6305.
 4. **Before June 2022, NDE bearing was 6306.

Outline Dimensions Sheet **MAXe3**

TECO Cast-Iron TEFC 3-Phase Squirrel-Cage Induction Motors

Frame 225 - 315M Foot and Flange Mount

Totally-Enclosed-Fan Cooled Squirrel-Cage Rotor

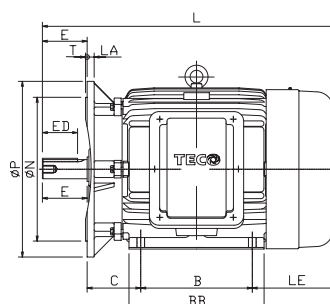
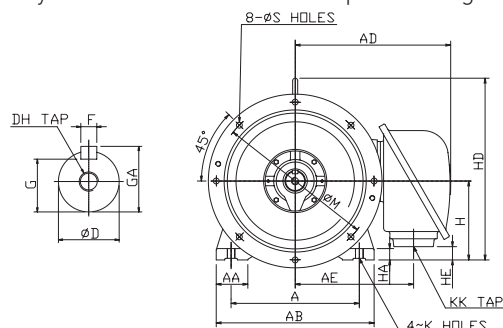

Fig. 4

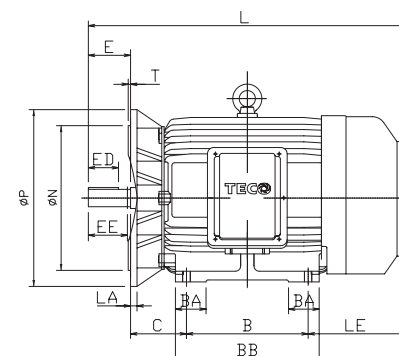

Fig. 5

Output (kW)				Frame Size	Fig. No.	Dimensions (mm)													
2P	4P	6P	8P			A	AA	AB	AD	AE	B	BB	C	H	HA	HD	HE	K	KK
-	37	-	18.5	225SC	4	356	90	450	386	330	286	350	149	225	30	524	57	19	M50 X 1.5
45	-	-	-	225MA	4	356	90	450	386	330	311	375	149	225	30	524	57	19	M50 X 1.5
-	45	30	22	225MC	4	356	90	450	386	330	311	375	149	225	30	524	57	19	M50 X 1.5
55	-	-	-	250SA	4	406	100	500	479	375	311	385	168	250	36	576	42	24	M63 X 1.5
-	55	37	30	250SC	4	406	100	500	479	375	311	385	168	250	36	576	42	24	M63 X 1.5
75	-	-	-	250MA	4	406	100	500	479	375	349	425	168	250	36	576	42	24	M63 X 1.5
-	75	45	37	250MC	4	406	100	500	479	375	349	425	168	250	36	576	42	24	M63 X 1.5
90	-	-	-	280SA	5	457	110	560	610	405	368	445	190	280	36	660	106	24	M63 X 1.5
-	90	55	45	280SC	5	457	110	560	610	405	368	445	190	280	36	660	106	24	M63 X 1.5
110	-	-	-	280MA	5	457	110	560	610	405	419	495	190	280	36	660	106	24	M63 X 1.5
-	110	75	55	280MC	5	457	110	560	610	405	419	495	190	280	36	660	106	24	M63 X 1.5
132	-	-	-	315SA	5	508	115	615	610	430	406	490	216	315	45	743	136	28	M63 X 1.5
-	132	90	75	315SC	5	508	115	615	610	430	406	490	216	315	45	743	136	28	M63 X 1.5
150 / 185	-	-	-	315MA	5	508	115	615	610	430	457	540	216	315	45	743	136	28	M63 X 1.5
-	150	110 / 132	90	315MC	5	508	115	615	610	430	457	540	216	315	45	743	136	28	M63 X 1.5
-	185	-	-	315MB	5	508	115	615	610	430	457	540	216	315	45	743	136	28	M63 X 1.5

Frame Size									Shaft Extension								Bearings	
	LA	LE	L	M	N	P	S	T	D	E	ED	EE	F	G	GA	DH	DE	NDE
225SC	22	241	816	400	350	450	19	5	60	140	110	-	18	53	64	M20 X 30	6313C3	6213C3
225MA	22	241	811	400	350	450	19	5	55	110	80	-	16	49	59	M20 X 30	6312C3	6212C3
225MC	22	241	841	400	350	450	19	5	60	140	110	-	18	53	64	M20 X 30	6313C3	6213C3
250SA	22	241	882	500	450	550	19	5	60	140	110	-	18	53	64	M20 X 30	6313C3	6313C3
250SC	22	263	882	500	450	550	19	5	70	140	110	-	20	62.5	74.5	M20 X 30	NU316C3	6313C3
250MA	22	263	920	500	450	550	19	5	60	140	110	-	18	53	64	M20 X 30	6313C3	6313C3
250MC	22	263	920	500	450	550	19	5	70	140	110	-	20	62.5	74.5	M20 X 30	NU316C3	6313C3
280SA	22	263	1042	500	450	550	19	5	65	140	110	134	18	58	69	M20 X 30	6314C3	6314C3
280SC	22	263	1042	500	450	550	19	5	80	170	140	157	22	71	85	M20 X 30	NU318C3	6316C3
280MA	22	344	1092	500	450	550	19	5	65	140	110	134	18	58	69	M20 X 30	6314C3	6314C3
280MC	22	344	1122	500	450	550	19	5	80	170	140	157	22	71	85	M20 X 30	NU318C3	6316C3
315SA	25	369	1131	600	550	660	24	6	65	140	110	134	18	58	69	M20 X 30	6314C3	6314C3
315SC	25	369	1161	600	550	660	24	6	85	170	140	157	22	76	90	M20 X 30	NU320C3	6316C3
315MA	25	369	1182	600	550	660	24	6	65	140	110	134	18	58	69	M20 X 30	6314C3	6314C3
315MC	25	369	1212	600	550	660	24	6	85	170	140	157	22	76	90	M20 X 30	NU320C3	6316C3
315MB	25	369	1042	600	550	660	24	6	85	170	140	157	22	76	90	M20 X 30	NU320C3	6316C3

- Notes:
1. Tolerance: Refer to page 33.
 2. Usable Shaft length: EE
 3. Data subject to change without notice and should not be used for installation purposes.
 4. * 6313C3 from July 2016 manufacture

Outline Dimensions Sheet **MAXe3**

TECO Cast Iron TEFC 3-Phase Squirrel - Cage Induction Motors

Frame 63 - 132 Foot and C Face Mount

Totally-Enclosed Fan-Cooled Squirrel-Cage Rotor

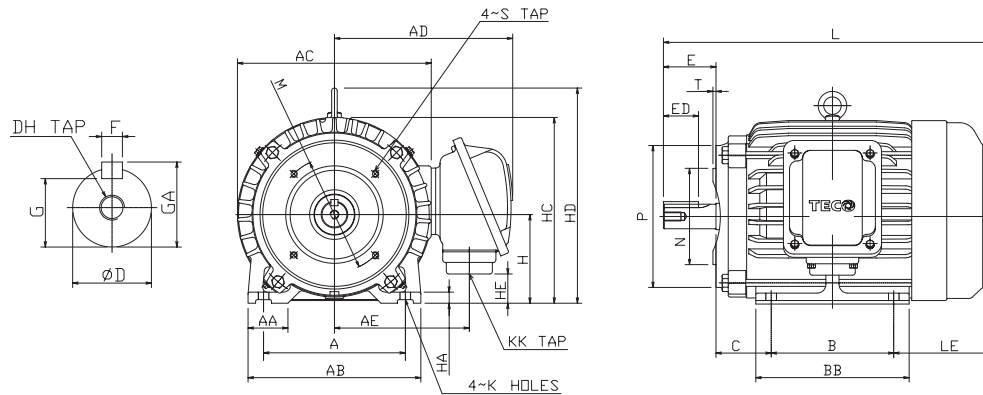

Output (kW)				Frame Size	Dimensions (mm)															
2P	4P	6P	8P		A	AA	AB	AC	AD	AE	B	BB	C	H	HA	HC	HD	HE	K	KK
0.18	0.18	-	-	63	100	28	120	144	123	97	80	100	40	63	8	135	-	10	7	M20x1.5
0.37 / 0.55	0.37	0.185	-	71	112	35.5	140	162	133	107	90	115	45	71	8	152	-	35	7	M20x1.5
0.75 / 1.1	0.55 / 0.75	0.37 / 0.55	0.18	80	125	35.5	155	177	179	130	100	130	50	80	9	168	-	13	10	M25x1.5
1.5	1.1	0.75	0.37	90S	140	35.5	170	200	192	143	100	130	56	90	10	190	-	23	10	M25x1.5
2.2	1.5	1.1	0.55	90L	140	35.5	170	200	192	143	125	150	56	90	10	190	-	23	10	M25x1.5
3	2.2 / 3	1.5	0.75 / 1.1	100L	160	45	195	219	202	153	140	175	63	100	12.5	-	243	33	12	M25x1.5
4	4	2.2	1.5	112M	190	45	224	238	211	162	140	175	70	112	14	-	265	45	12	M25x1.5
5.5 / 7.5	5.5	3	2.2	132S	216	45	250	273	249	187	140	175	89	132	16	-	310	58	12	M25x1.5
-	7.5	4 / 5.5	3	132M	216	45	250	273	249	187	178	212	89	132	16	-	310	58	12	M25x1.5

Frame Size	Flange				Shaft Extension								Bearings				
	LA	LE	L	M	N	P	S	T	D	E	ED	F	G	GA	DH	DE	NDE
63	12	23	248	75	60	90	M5	3	11	23	18	4	8.5	12.5	M4x8	6201ZXC3	6201ZXC3
71	12	40	277	85	70	105	M6	3.5	14	30	24	5	11	16	M5x10	6202ZXC3	6202ZXC3
80	12	50	282	100	80	120	M6	3.5	19	40	25	6	15.5	21.5	M6x12	6204ZXC3	6204ZXC3
90S	12	50	346	115	95	140	M8	3.5	24	50	32	8	20	27	M8x16	6205ZXC3	6205ZXC3
90L	12	50	371	115	95	140	M8	3.5	24	50	32	8	20	27	M8x16	6205ZXC3	6205ZXC3
100L	16	60	374	130	110	160	M8	4	28	60	40	8	24	31	M10x20	6206ZXC3	6205ZXC3*
112M	16	60	431	130	110	160	M8	4	28	60	40	8	24	31	M10x20	6306ZXC3	6206ZXC3**
132S	20	80	454	165	130	200	M10	4	38	80	64	10	33	41	M12x24	6308ZXC3	6306ZXC3
132M	20	80	492	165	130	200	M10	4	38	80	64	10	33	41	M12x24	6308ZXC3	6306ZXC3

- Notes:**
1. Tolerance: Refer to page 33.
 2. Eyebolts not provide of frames D90 and smaller
 3. *Before June 2022, NDE bearing was 6305.
 4. **Before June 2022, NDE bearing was 6306.

Mechanical Design



Axial / Radial Loadings

The table below gives the permissible axial and radial loads. The values are based on normal conditions at 50 Hz and a calculated L10 bearing life of 40,000 hours.

Frame Size	Radial Load Horizontal Shaft	Axial Load Horizontal Shaft	Axial Load Shaft Down (down thrust)	Axial Load Shaft Down (up thrust)
80	47 kg	69 kg	65 kg	73 kg
90	49 kg	73 kg	66.5 kg	79.5 kg
100	72 kg	105 kg	95 kg	115 kg
112	95 kg	138 kg	124 kg	152 kg
132	147 kg	143 kg	123 kg	163 kg
160	179 kg	174 kg	134 kg	214 kg
180	248 kg	238 kg	182 kg	292 kg
200	297 kg	290 kg	210 kg	370 kg
225	305 kg	310 kg	230 kg	390 kg
250	1400 kg	325 kg	320 kg	510 kg
280	1500 kg	-	-	-
315M	1650 kg	-	-	-

- Notes:**
1. Based on 4 Pole motors, bearing life L-10 40,000 hours.
 2. For radial load overhung point at centre of shaft extension.
 3. For other loadings, please contact TECO.

Axial Radial Loadings - Foot

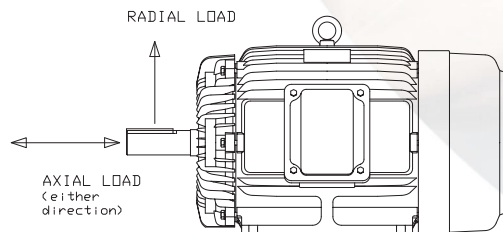

Axial Radial Loadings - Flange

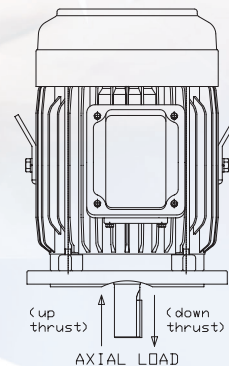

Cooling

Designation System Concerning Methods of Cooling Refers to Standard AS1359.106.

Standard Code Example

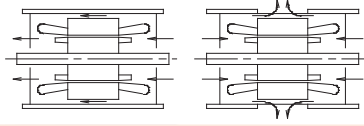
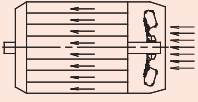
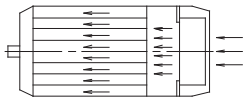
Code	Description	Type
IC 01	Self-cooling open machine.	
IC411	Enclosed machine. Smooth or finned ventilated casing. External shaft-mounted fan.	
IC416	Enclosed machine. Smooth or finned ventilated casing. External motorized axial fan supplied with machine.	

Example

Code	IC	4	(A)	1	(A)	6
International Cooling						
Circuit Arrangement						
Primary Coolant						
Method of Movement of Primary Coolant						
Secondary Coolant						
Method of Movement of Secondary Coolant						

Cooling air flows from the non-drive-end to the drive end. When the motor is installed care should be taken not to impede the airflow into the motor fan cover. As a guide the following minimum dimension BL should be adopted.

Motor Frame	Dimensions BL (mm)
80 - 100	60
112 - 132	85
160 - 180	85
200 - 250	110
280	140
315 - 355	180

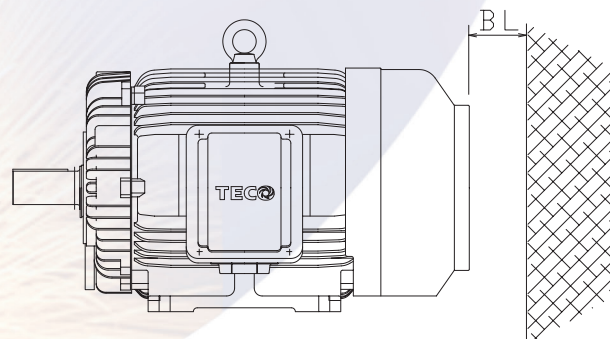

Forced Cooling IC416

TECO can offer forced cooling on most TEFC motors, listed below are common sizes with details (larger sizes please refer to TECO). All forced cooling motors are 230 ~ 240 Volts Single-Phase 50Hz and are IP55 as standard. Fan motor leads are terminated in an auxiliary terminal box mounted on the fan cover.

Frame Size	Motor Watts	Amps	Force Cooling Unit length "Lfc" in mm
D80	17	0.1	95
D90	29	0.12	95
D100	29	0.12	90
D112	46	0.22	105
D132	46	0.22	85
D160	75	0.42	140
D180	75	0.42	135
D200	135	0.59	95

Notes: 1. Dimensions subject to change.

*Typical Force Cooling Unit.
View from the inside.*



Force Cooling Lfc

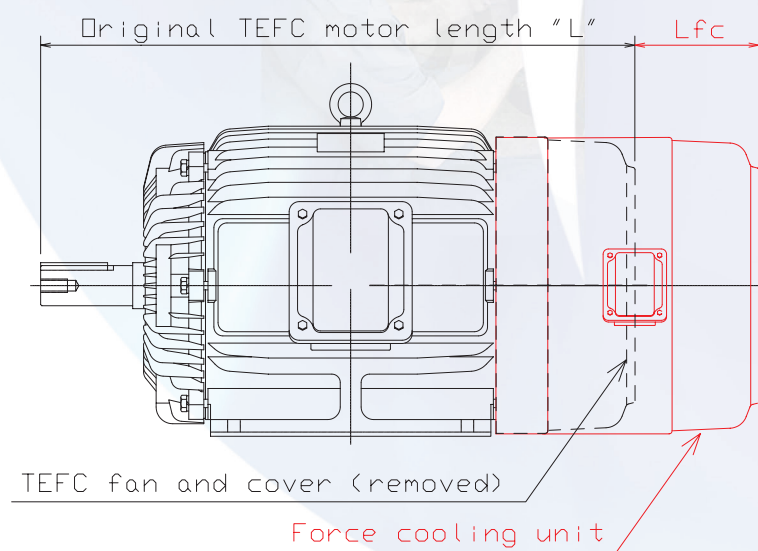

Mounting (IM code)

Mounting Arrangement (IM)

Foot Mounted		Flange Mounted		Foot / Flange Mounted	
IM 1001 (IM B3) Horizontal Shaft. Foot mounted.		IM 3001 (IM B5) Horizontal Shaft. 'D' type flange at D.E. No feet.		IM 2001 (IM B35) Horizontal Shaft. 'D' type flange at D.E. Foot mounted.	
IM 1051 (IM B6) Horizontal Shaft. Foot wall mounted with feet on left-side when viewed from D.E.		IM 3011 (IM V1) Vertical Shaft. 'D' type flange at D.E. Shaft down. No feet.		IM 2011 (IM V15) Vertical Shaft. 'D' type flange at D.E. Wall mounted. Shaft down.	
IM 1061 (IM B7) Horizontal Shaft. Foot wall mounted with feet on right-side when viewed from D.E.		IM 3031 (IM V3) Vertical Shaft. 'D' type flange at D.E. Shaft up. No feet.		IM 2031 (IM V36) Vertical Shaft. 'D' type flange at D.E. Wall mounted. Shaft up.	
IM 1071 (IM B8) Horizontal Shaft. Ceiling mounted with feet above motor.		IM 3601 (IM B14) Horizontal Shaft. 'C' type flange at D.E. No feet.		IM 2101 (IM B34) Horizontal Shaft. 'C' type flange at D.E. Foot mounted.	
IM 1011 (IM V5) Vertical Shaft. Wall mounted. Shaft down.		IM 3611 (IM V18) Vertical Shaft. 'C' type flange at D.E. Shaft down. No feet.		IM 2111 Vertical Shaft. 'C' type flange at D.E. Wall mounted. Shaft down.	
IM 1031 (IM V6) Vertical Shaft. Wall mounted. Shaft up.		IM 3631 (IM V19) Vertical Shaft. 'C' type flange at D.E. Shaft up. No feet.		IM 2131 Vertical Shaft. 'C' type flange at D.E. Wall mounted. Shaft up.	

It is important to nominate the "IM" code at enquiry and order stage to ensure that drain holes are in the correct position and the bearing arrangement is checked for suitability if the "IM" code differs from standard.

Standard Mounting Arrangement

TECO Stock Motors - Standard Mounting Arrangement and Terminal Box Position				
Mounting	IM Code	(IM Code)	Terminal box position (viewed from drive end)	Cable entry direction
Foot	IM1001	IMB3	Right	From below
Flange	IM3011	IMV1	As needed (motor can be rotated)	From flange end
Foot & Flange	IM2001	IMB35	Right	From below

Mounting - Cast - Iron - Slide Rails - Dimensions

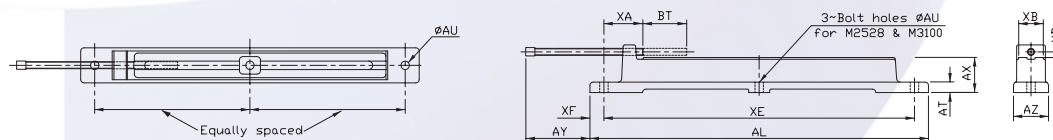





SLIDE RAIL	FRAME SIZE	AL	AT	AU	AX	AY	AZ	BT min.	XA max.	XB	XD	XE	XF
M0809	80	355	12	10	30	105	35	95	45	30	6	325	15
	90	355	12	10	30	105	35	80	45	30	6	325	15
M1013	100	470	16	12	44	170	52	160	50	43	6	430	18
	112	470	16	12	44	170	52	125	50	43	6	430	18
	132	470	16	12	44	170	52	100	50	43	6	430	18
M1618	160	615	19	15	64	170	76	155	67	57	11	565	25
	180	615	19	15	64	170	76	125	67	57	11	565	25
M2022	200	780	25	19	82	210	100	190	80	82	12	725	27
	225	780	25	19	82	210	100	140	80	82	12	725	27
M2528	250	965	30	24	100	275	100	250	86	82	16	885	40
	280	965	30	24	100	275	100	190	86	82	16	885	40
M3100	315M	1215	40	38	125	380	123	330	110	95	20	1115	50

Larger sizes please refer to TECO.

Protection (IP code)

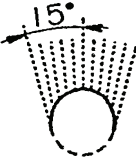
Protection (IP)

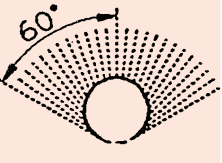
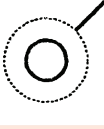
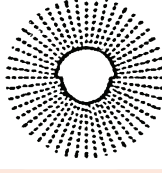
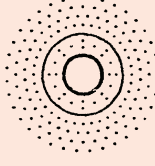
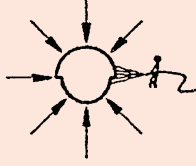
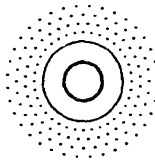
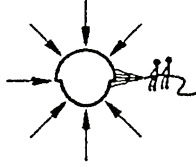
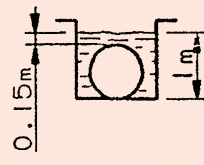
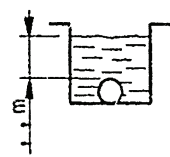
First number: Protection against solid objects			Second number: Protection against liquids		
IP	Tests	Definition	IP	Tests	Definition
0		No protection.	0		No protection.
1	<p>∅50mm</p> 	Protected against solid objects of over 50mm (e.g. accidental hand contact).	1		Protected against vertically dripping water (condensation).
2	<p>∅12mm</p> 	Protected against solid objects of over 12mm (e.g. finger).	2		Protected against water dripping up to 15° from the vertical.
3	<p>∅2.5mm</p> 	Protected against solid objects of over 2.5mm (e.g. tools, wire).	3		Protected against rain falling at up to 60° from the vertical.
4	<p>∅1mm</p> 	Protected against solid objects of over 1mm (e.g. thin wire).	4		Protected against water splashes from all directions.
5		Protected against dust (e.g. no deposits of harmful material).	5		Protected against jets of water from all directions.
6		Totally protected against dust.	6		Protected against jets of water comparable to heavy seas.
			7		Protected against effects of immersion to depths of between 0.15 and 1m.
			8		Protected against the effects of prolonged immersion at depth.

Electrical Design

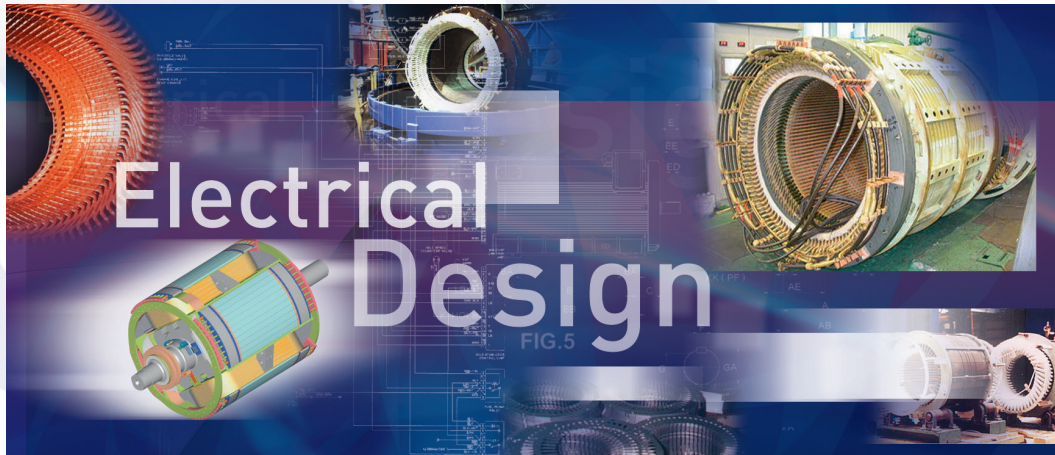

Altitude and Ambient Temperature

Rated output power specified in the performance data tables apply for standard ambient conditions of 40°C up to 1000 m above sea level. Where temperature or altitude differ from the standard, multiplication factors in the table below should be used if motor temperature rise is to be maintained. (Refer note 2 below).

Ambient Temperature	Temperature Factor	Altitude above sea level	Altitude Factor
30°C	1.06	1000 m	1
35°C	1.03	1500 m	0.97
40°C	1	2000 m	0.945
45°C	1	2500 m	0.92
50°C	1	3000 m	0.89
55°C	1	3500 m	0.865
60°C	0.97 / 1.0*	4000 m	0.835
25°C	0.97 / 1.0*	4500 m	0.740

- Notes:**
1. Effective Power = (Rated Power) x (Temperature Factor) x (Altitude Factor)
 2. The low temperature rise of TECO motors in many instances preclude the need for derating. Larger sizes please refer to TECO.
 3. Refer page 2 for permissible ambients for MAXe3 motors.
 4. * 60°C, PSD / Mining

Earth Topography

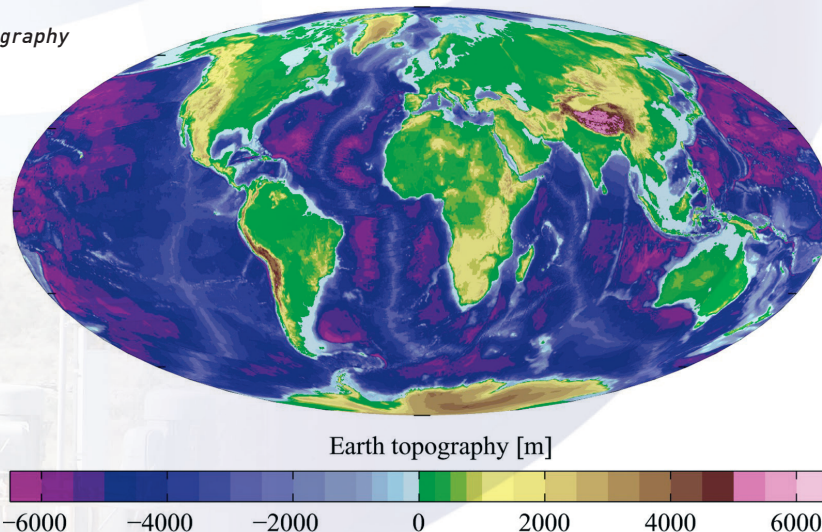

Anti-Condensation Heaters (Optional)

Anti-condensation heaters are used to prevent the water accumulation caused by moisture condensation inside the motor. These are flexible type elements and tied on the ends of the winding to maintain the average temperature of the motor above dew point. The heaters must be switched on when the machine stops and switched off whilst the machine is in operation. A prominent warning label is fitted with the appropriate rating of the heaters nominated.

The anti-condensation heater leads are normally terminated to an auxiliary terminal box for safety reasons.

The normal supply of anti-condensation heaters is single phase 240V, other voltages can be supplied upon request.

Power Rating of Anti-Condensation Heaters

Heater length varies to suit diameter of end-winding.

Frame Size	Power in Watts
80 ~ 100	25
112	21
132 ~ 160	40
180 ~ 200	26
225 ~ 250	42
280	54
315M	99
315A	200
355	250

Heater Nameplate

ANTI- CONDENSATION HEATERS		
Type FACH	V	W
WARNING Heaters must be switched OFF when the motor is energised		
TM 95121		

Connection Diagrams

TECO motors are connected as shown on the motor nameplate, the typical Star or Delta connection diagrams are shown below.

TECO stock motors 4 kW and below are 380~415 Volt 50 Hz STAR connected and may

also be reconnected to 240 Volt 3-Phase 50 Hz DELTA configuration for use with single phase input inverters.

Motors 5.5 kW and larger are 380~415 Volt 50 Hz DELTA connected.

STAR CONNECTION

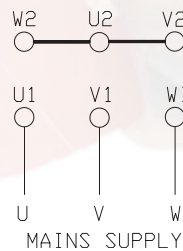

DELTA CONNECTION

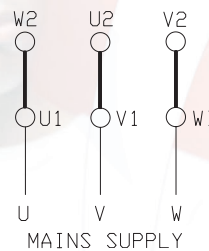

MAXe3 MINING AFJE D315A-355

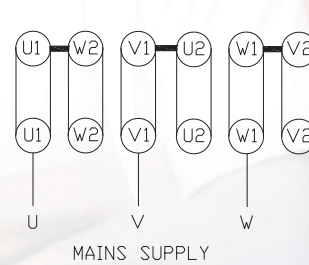
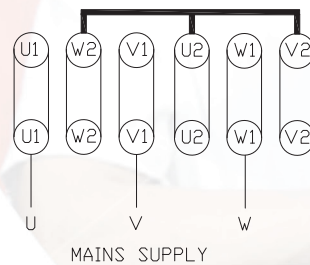

Duty

TECO motors are supplied suitable for S1 operation (continuous operation under rated load). When the motor is to operate under any other type of duty the following information should be supplied to determine the correct motor size.

- Type and frequency of switching (short time, intermittent, periodic, high inertia, braking).

- Load torque variation during motor acceleration and braking (in graphical form).
- Moment of inertia of the load on the motor shaft.
- Type of braking (e.g. mechanical, electrical through phase reversal or DC injection.)
- For duty cycles other than S1 please refer to TECO.

Efficiency

Energy use is the dominant source of green-house gas emissions in Australia & New Zealand.

TECO is committed to producing high efficiency motors in order to reduce the energy consumed and in turn reduce green house gas emissions.

TECO **MAXe3** motors meet the High Efficiency requirements (IE3) of IEC60034-30 under the scope of GEMS Determination.

This line provides the best payback periods and the lowest cost of ownership.

The graph below shows the comparison of **TECO MAXe3 High Efficiency Motors** against the current MEPS 2018 levels (IEC60034-30).

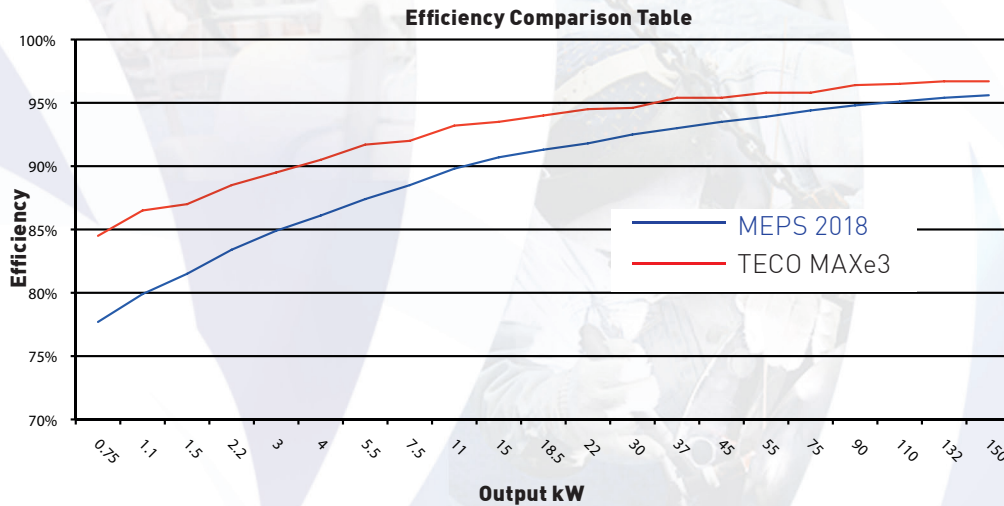

Operating Cost Saving

How much money can be saved in the first year of operation? Typical cost saving on a 75 kW 4 Pole motor can be calculated as follows:

$$S = \text{kW} \times N \times C \left(\frac{100}{E1} - \frac{100}{E2} \right)$$

S = Savings in \$ per year

KW = Rated motor output (kW) = 75

C = Energy cost per kW/hr = \$ 0.25

N = Running time in hrs/year = 8760 hrs

E1 = Efficiency of a standard motor (MEPS2000) = 93.6%

E2 = Efficiency of TECO MAX e3™ motor = 95.7%

Calculation Example:

Operational cost saving per year

$$S = 75 \times 8760 \times 0.25 \times \left(\frac{100}{93.6} - \frac{100}{95.7} \right) = \$ 3,851$$

Saving over a 20 year period = \$ 77,020

Typical Total cost of ownership of an electric motor

- The purchase price is only the tip of the iceberg! (based on 2000 hr PA, 20 year life).

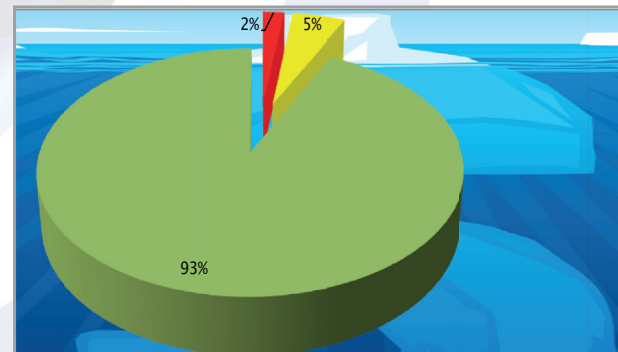

- Motor purchase price
- Installation and maintenance
- Running cost (energy consumption)

Cost saving on the environment?

Electric motors are responsible for the industrial and commercial sectors. crushing, grinding, mixing, fans, compressors, ventilation and estimate that electric motors electricity consumption in Australia or around 11% of total greenhouse

TECO MAXe3 High Efficiency Motors money but also reduce



majority of electricity consumption in the Typical applications include pumps, materials conveying, air refrigeration. In total, experts account for nearly 45% of total and New Zealand for all sectors gas emissions. By utilising you will not **only save** our carbon foot print.

Formulae and Conversions

Electric Motor characteristics

Output Power

$$P \text{ (kW)} = \frac{M \times n}{9550}$$

Output Power

$$P_{\text{mec}} = \frac{\sqrt{3} \times U \times I \times \cos \phi \times \eta}{1000}$$

Output Torque

$$M = \frac{9550 \times P}{n}$$

Star Delta Starting

$$\text{Torque (Star)} = \frac{\text{Full Load Torque (Delta)}}{0.333}$$

$$\text{Current (Star)} = \frac{\text{Full Load Current (Delta)}}{0.577}$$

3-Phase Input Power

$$P_{\text{el}} = \frac{\sqrt{3} \times U \times I \times \cos \phi}{1000}$$

Efficiency

$$\eta = \frac{\text{Output kW}}{\text{Input kW}}$$

$$\eta = \frac{P_{\text{mec}} \times 1000}{\sqrt{3} \times U \times I \times \cos \phi}$$

Motor Current

$$I = \frac{P_{\text{mec}} \times 1000}{\sqrt{3} \times U \times \cos \phi \times \eta}$$

$$I = \frac{P_{\text{elec}} \times 1000}{\sqrt{3} \times U \times \cos \phi}$$

I = Motor current can be calculated for full or partial loadings.

Use Efficiency and Power Factor relative to motor loadings.

Motor Synchronous Speed

$$n = 120 \times \frac{f}{\text{Poles}}$$

Hz	Number of Poles - Synchronous Speed					
	2	4	6	8	10	12
50	3000	1500	1000	750	600	500
60	3600	1800	1200	900	720	600

Key: P = Power in kW
Subscript
 P_{el} = electrical
 P_{mec} = mechanical

M = Torque in Nm
 n = Rotational speed in r/min
 U = Line voltage in V
 I = Line current in A
 cos φ = Power factor (per unit)
 η = Motor efficiency (per unit)
 f = Frequency in Hz
 J = WR² = WK²

Conversions

Length

	m	cm	mm
1 m =	1	100	1000
1 mm =	0.001	0.1	1
1 ft =	0.3048	30.48	304.8
1 in =	0.254	2.54	25.4

m = meter, cm - centimeter, mm = millimeter

Force and weight

	N	kp	p
1 N =	1	0.102	102
1 kp =	9.807	1	1000
1 lbf =	4.448	0.4536	453.6
1 in =	0.254	2.54	25.4

Velocity

	km/h	m/min	m/s
1 km/h =	1	16.667	0.2778
1 m/min =	0.06	1	16.7 x 10 ⁻³
1 m/s =	3.6	60	1
1 in =	0.254	2.54	25.4

Torque

	Nm	kgfm
1 Nm =	1	0.10197
1 kgfm =	9.8067	1
1 lbf.ft =	1.356	0.1383
1 lbf.in =	0.1129	11.5 x 10 ⁻³

Power

	kW	hp
1 kW =	1	1.341
1 hp =	0.7457	1

Moment of Inertia

	kgm ² (J)	kgfm ² (GD ²)
1 kgm ² (J) =	1	4
1 kgfm ² (GD ²) =	0.25	1

Insulation Classes

The graph below indicates the limits of winding temperature and temperature rise for the various insulation classes in accordance with AS60034-1 Items 1b) & 1d) AC motors.

The difference between the temperature rise and the insulation class rating equates to the safety margin available.

The majority of TECO motors comply with a limitation of Class E temperature rise (75°C) or less, thereby providing a massive thermal reserve, which provides the client with a motor that will perform extremely well in arduous temperature applications (whether load or ambient induced).

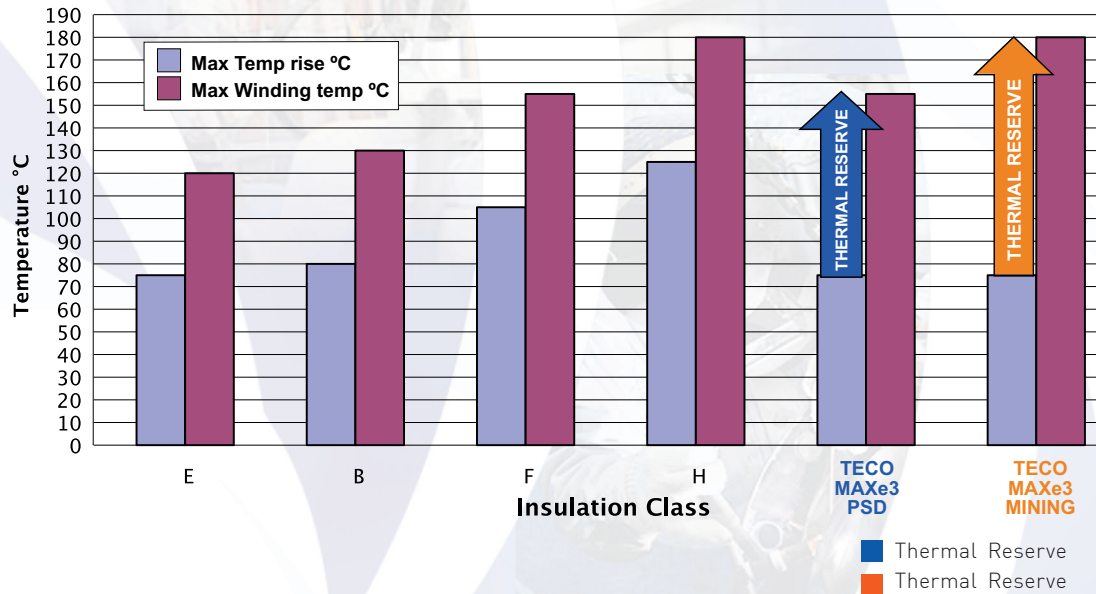

Speed vs. Torque - Current

The graph below indicates the typical speed vs. torque current characteristics of a D132 frame motor to "Design N" Normal Torque. The motor is started DOL and the major points on these curves are defined below.

Speed vs. Torque - Current Curves

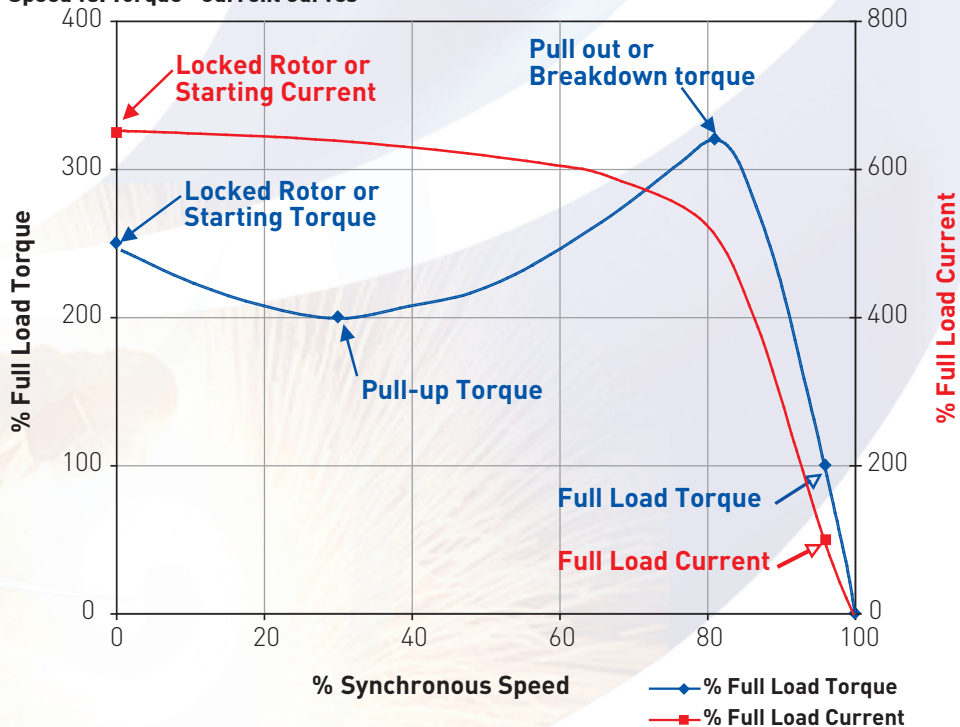

Starts Per Hour

Starts Per Hour and Maximum Load Inertia

Maximum starts per hour DOL based on maximum load inertia listed, these are quoted as equally spaced and includes one cold start.

For larger inertias and / or greater frequency of starting please refer to TECO.

Starts Per Hour (Based on Maximum Load Inertia)

Pole	Frame Size					
	80 - 112	132 - 160	180 - 200	225 - 250	280	315M
2	12	10	8	5	3	3
4	22	20	16	10	6	4
6	28	25	20	12	8	6

Maximum Allowable Load Inertia

kW	Load Inertia							
	GD ² Kg-m ²	WR ² Kg-m ²	GD ² Kg-m ²	WR ² Kg-m ²	GD ² Kg-m ²	WR ² Kg-m ²	GD ² Kg-m ²	WR ² Kg-m ²
	2 Pole		4 Pole		6 Pole		8 Pole	
0.75	0.325	0.081	1.41	0.353	3.65	0.913	7.54	1.89
1.1	0.440	0.110	2.09	0.523	5.60	1.40	11.0	2.74
1.5	0.580	0.145	2.68	0.670	7.30	1.83	14.6	3.65
2.2	0.850	0.213	4.14	1.04	10.7	2.68	21.2	5.29
3	1.12	0.280	5.35	1.34	14.0	3.50	27.9	6.97
4	1.53	0.383	7.23	1.81	19.0	4.75	38.0	9.51
5.5	2.02	0.505	9.49	2.37	25.3	6.33	50.6	12.7
7.5	2.68	0.670	12.4	3.10	33.3	8.34	66.4	16.6
11	3.89	0.973	18.3	4.57	48.7	12.2	97.3	24.3
15	5.11	1.28	24.1	6.02	63.8	15.9	127	31.8
18.5	6.20	1.55	29.7	7.42	78.8	19.7	157	39.2
22	7.54	1.89	35.1	8.76	93.5	23.4	187	46.8
30	9.73	2.43	46.0	11.5	122	30.5	245	61.2
37	11.9	2.98	56.5	14.1	151	37.8	302	75.5
45	14.1	3.53	66.9	16.7	179	44.8	358	89.5
55	17.3	4.32	82.2	20.6	220	55.0	441	110
75	22.4	5.60	107	26.8	187	46.8	577	144
90	27.5	6.88	132	33.0	353	88.2	710	178
110	32.3	8.08	156	39.0	418	105	*	*
132	36.5	9.13	176	44.0	481	120	*	*
150	41.8	10.5	202	50.5	*	*	*	*
185	51.1	12.8	247	61.8	*	*	*	*

Notes: * For larger sizes please refer to TECO.

Thermal Protection

The various types of thermal protection devices are described below. Whilst these devices provide excellent thermal protection they may not fully protect against some transient conditions.

Additional set(s) of these protection devices can be provided with a lower temperature rating which can be utilized as an alarm function. Higher temperature ratings can be supplied for higher trip temperatures, however, care should be taken to ensure the temperature rating of the insulation class is not compromised.

Thermistors

Thermistors are thermo-variable resistors and have a positive temperature co-efficient (PTC). Three thermistors are fitted to the end-windings (one per phase), which are connected in series. The standard TECO thermistors at trip temperature have a resistance of 1000 ohms per thermistor (3000 ohms total, 3 thermistors, one per phase).

Thermistors are sensors that require connection to a control relay (this relay is not supplied by TECO).

The leads normally are terminated in the main terminal box (with an auxiliary terminal box available if specified).

Temperature vs. Resistance Diagram

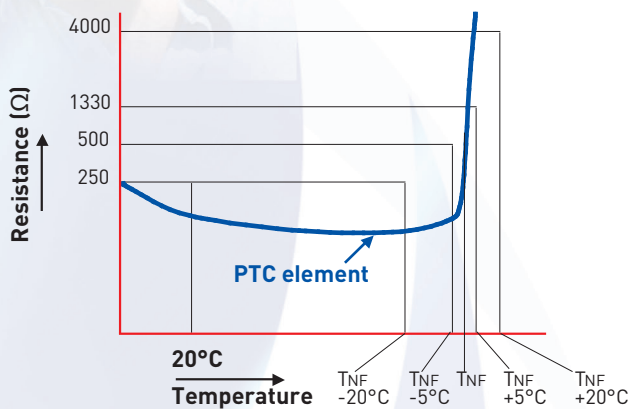

Connection Lead Colour Coding

Trip Temperature (°C)	Lead Wire Colours	
90	GREEN	GREEN
100	RED	RED
110	BROWN	BROWN
120	GREY	GREY
130	BLUE	BLUE
140	WHITE	BLUE
150	BLACK	BLACK
160	BLUE	RED
170	WHITE	BLACK
180	WHITE	RED

Thermistors and / or RTD's should not be Meggered or tested at a voltage above 2.5 volts.

Typical Thermistor Nameplates

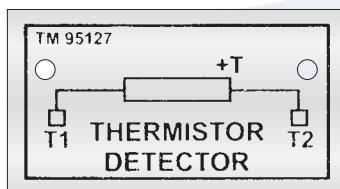

Resistance Temperature Detectors (RTDs)

An RTD, (Resistance Temperature Detector), is a device that provides a change in resistance value in relationship to temperature.

This change is of a linear nature thereby providing the ability to accurately monitor the motor operating temperatures when connected to an appropriate relay.

The most commonly used RTD is the platinum type which has a nominal resistance of 100ohms @ 0°C (PT100) and is of the 3 wire type (other RTD types available on application).

When fitted the RTD leads are terminated to an auxiliary terminal box (it is recommended that external wiring to this box be of the screened copper conductor type to prevent any electromagnetic interference).

- Winding RTDs can be provided within the windings, one per phase or more as required.
- Bearing RTDs can be provided if required. The RTD element is located in a stainless-steel metal probe and is mounted within a bearing thermowell.

"3 wire" RTD circuit

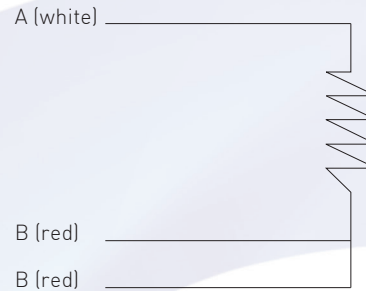

Table for Platinum Resistance Elements (Resistance in Ohms vs. Temperature) e.g. 19°C = 107.40 Ohms

°C	0	1	2	3	4	5	6	7	8	9
0	100.00	100.39	100.78	101.17	101.56	101.95	102.34	102.73	103.12	103.51
10	103.90	104.29	104.68	105.07	105.46	105.85	106.24	106.63	107.02	107.40
20	107.79	108.18	108.57	108.96	109.35	109.73	110.12	110.51	110.90	111.28
30	111.67	112.06	112.45	112.83	113.22	113.61	113.99	114.38	114.77	115.15
40	115.54	115.93	116.31	116.70	117.08	117.47	117.85	118.24	118.62	119.01
50	119.40	119.78	120.16	120.55	120.93	121.32	121.70	122.09	122.47	122.86
60	123.24	123.62	124.01	124.39	124.77	125.16	125.54	125.92	126.31	126.69
70	127.07	127.45	127.84	128.22	128.60	128.98	129.37	129.75	130.13	130.51
80	130.89	131.27	131.66	132.04	132.42	132.80	133.18	133.56	133.94	134.32
90	134.70	135.08	135.46	135.84	136.22	136.60	136.98	137.36	137.74	138.12
100	138.50	138.88	139.26	139.64	140.02	140.39	140.77	141.15	141.53	141.91
110	142.29	142.66	143.04	143.42	143.80	144.17	144.55	144.93	145.31	145.68
120	146.06	146.44	146.81	147.19	147.57	147.94	148.32	148.70	149.07	149.45
130	149.82	150.20	150.57	150.95	151.33	151.70	152.08	152.45	152.83	153.20
140	153.58	153.95	154.32	154.70	155.07	155.45	155.82	156.19	156.57	156.94
150	157.31	157.69	158.06	158.43	158.81	159.18	159.55	159.93	160.30	160.67
160	161.04	161.42	161.79	162.16	162.53	162.90	163.27	163.65	164.02	164.39
170	164.76	165.13	165.50	165.87	166.24	166.61	166.98	167.35	167.72	168.09
180	168.46	168.83	169.20	169.57	169.94	170.31	170.68	171.05	171.42	171.79
190	172.16	172.53	172.90	173.26	173.63	174.00	174.37	174.74	175.10	175.47
200	175.84	176.21	176.57	176.94	177.31	177.68	178.04	178.41	178.78	179.14

Recommend Temperature Settings for RTDs

Device	Type	Location	Alarm	Trip
RTD	Platinum 100 Ohms @ 0°C	Winding, Class F	140°C	150°C
RTD	Platinum 100 Ohms @ 0°C	Winding, Class H	160°C	170°C
RTD	Platinum 100 Ohms @ 0°C	DE & NDE Bearing	95°C	100°C

Tolerances for Electromechanical Characteristics

AS60034-1 Specifies Standard Tolerances for Electromechanical Characteristics (Squirrel Cage Induction Motors)

Quantity	Tolerance
Efficiency (Losses)	-15% (1- η)
Power factor (Cos ϕ)	-1/6 (1-cos ϕ) min. 0.02, max. 0.07
Slip P < 1 kW	\pm 30% of the slip
Slip P \geq 1 kW	\pm 20% of the slip
Starting torque	-15%, +25% of the torque
Starting current	+20% of the current
Pull-up torque	-15% of the torque
Break down torque	-10% of the torque >1.5 full load torque

IEC60072 Dimensional Tolerances

Shaft Height

Dimension "H"

Frame Size	Tolerance	Tolerance (mm)
63 to 250		+ 0
		- 0.5
280 to 450		+ 0
		- 1

Shaft

Dimension "D".

D	Tolerance	Tolerance (mm)
14	j6	+ 0.008
		- 0.003
19 to 28	j6	+ 0.009
		- 0.004
32 to 48	k6	+ 0.018
		+ 0.002
55 to 80	m6	+ 0.030
		+ 0.011
85 to 120	m6	+ 0.035
		+ 0.013
125	m6	+ 0.040
		+ 0.015

Flange

Dimension "N"

N	Tolerance	Tolerance (mm)
110	h7	+ 0
		- 0.035
130 & 180	h7	+ 0
		- 0.040
230 & 250	h7	+ 0
		- 0.046
300	h7	+ 0
		- 0.052
350	h7	+ 0
		- 0.057
450	h7	+ 0
		- 0.063
550	h7	+ 0
		- 0.070

C Face

Dimension "N"

N	Tolerance	Tolerance (mm)
60 to 80	h7	+ 0
		- 0.030
95 & 110	h7	+ 0
		- 0.035
130	h7	+ 0
		- 0.040

Variable Speed Drives (VVVF)

The voltage output of Variable Voltage Variable Frequency (VVVF) Drives is not purely sinusoidal. This causes higher voltage stresses within the windings and increases the losses, vibration, and noise of the motor. The Loadability Curve and Maximum Safe Speed are as below, (this graph should be used as a guide only). Further consultation with TECO may be required for arduous critical speed and load duties, or for Ex rated areas.

Typical Motor Loadability Curve

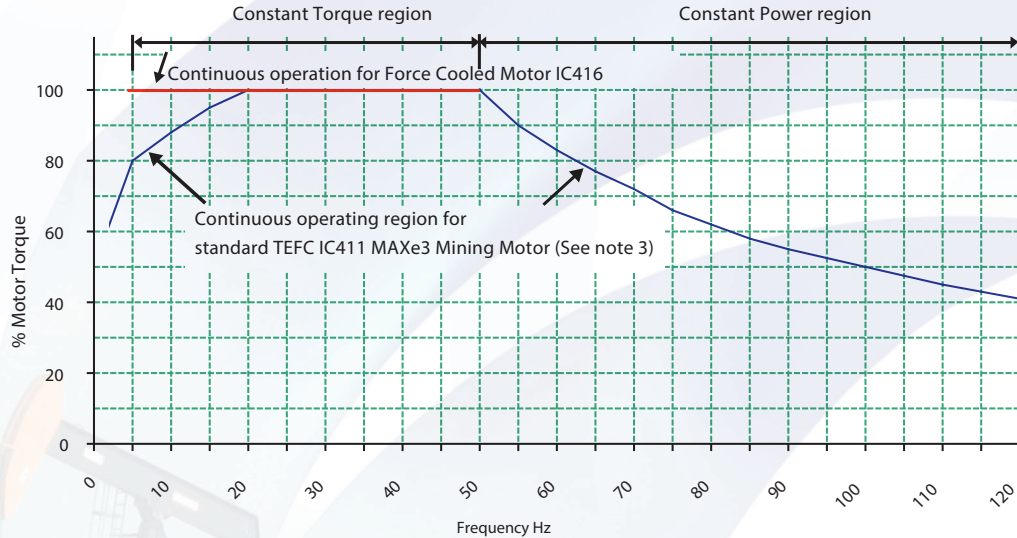

- Notes:**
1. Installation: to follow the guidelines detailed in "AS60034-17:2006 Cage induction motors when fed from converters - Application guide".
 2. Maximum safe operating speed to follow AS60034-1, Table 17.
 3. MAXE3 Premium Severe Duty constant torque to 25 Hz.

For variable torque loads (centrifugal pumps and fans) for speeds between 5-50 Hz derating is not normally required. Outside of this range please check with TECO for motor suitability.

Typical variable and constant torque load curves are shown below.

Speed vs. Torque Curves (assuming load torque @ 100% speed = motor full load torque)

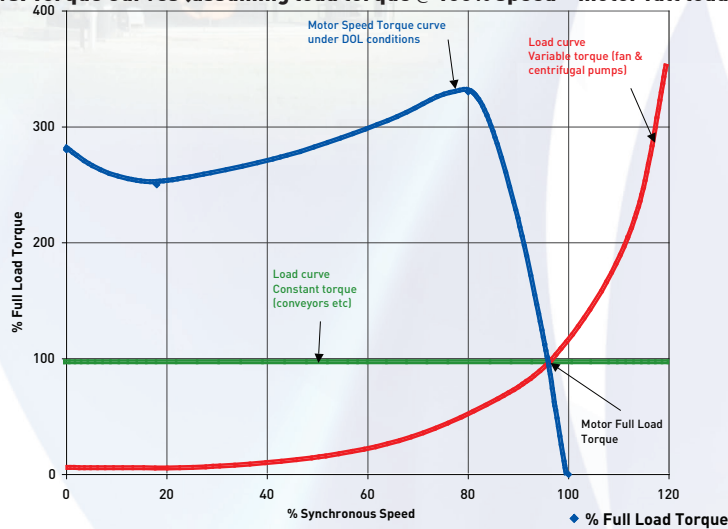

Maximum Safe Operating Speed (RPM), According to IEC60034-1 (Table 18)

Frame Number	2 Pole	4 Pole	6 Pole
≤ 112	5200	3600	2400
132 ~ 180	4500	2700	2400
200	4500	2300	1800
225 ~ 315	3600	2300	1800

Note: Rotors are balanced up to 3600 RPM. If the motor is going to operate above 3600 RPM (2 pole motor at 60 Hz), special balancing/rebalancing the rotor should be required.

Variable Speed Drives (VVVF) *continued*

Motor Synchronous Speed vs. Frequency

Motor Synchronous Speed vs. Frequency																									
Frequency (Hz)	0	5	10	15	20	25	30	35	40	45	50	55	60	65	70	75	80	85	90	95	100	105	110	115	120
2 Pole RPM	0	300	600	900	1200	1500	1800	2100	2400	2700	3000	3300	3600	3900	4200	4500	4800	5100	5400	5700	6000	6300	6600	6900	7200
4 Pole RPM	0	150	300	450	600	750	900	1050	1200	1350	1500	1650	1800	1950	2100	2250	2400	2550	2700	2850	3000	3150	3300	3450	3600
6 Pole RPM	0	100	200	300	400	500	600	700	800	900	1000	1100	1200	1300	1400	1500	1600	1700	1800	1900	2000	2100	2200	2300	2400
8 Pole RPM	0	75	150	225	300	375	450	525	600	675	750	825	900	975	1050	1125	1200	1275	1350	1425	1500	1575	1650	1725	1800

TECO Squirrel-Cage Induction Motors on Variable Speed Drives

Drawing on both TECO and Westinghouse expertise, TECO motors are designed with an advanced insulation system to meet the severe demands of modern inverters. TECO motors meet or exceed the recommendations of IEC 60034-17 and IEC 60034-25. All TECO motors are designed with an enhanced insulation system, including spike-resistant wire capable of withstanding the high-voltage stresses generated by modern PWM inverters.

Low Voltage Motors: TECO Low Voltage insulation system are rated as follows:					
Motor Low Voltage	Insulation Class	Winding Insulation (phase - phase)		Rise Time	Time between pulses
		Peak Voltage on Motors terminal	dV/dt on Motors terminal		
TECO AUS & NZ	F	< 1,600 V	< 6,500 V/μS	≥ 0.1μS	≥ 6μS
L.V. stock motor	H	< 2,200 V	< 8,500 V/μS		

Please refer to IEC 60034-25 and IEC 60034-18-41 for further information on the responsibility of specification and compliance with stress levels for the Power Drive System (PDS).

Providing the recommendations above are adhered to, all TECO Australia and New Zealand 3-Phase stock motors 380~415 Volt Delta connected are suitable for 690 Volt Star connection for both VSD or DOL starting (subject to load torque and speed limitations - please refer to TECO).

In addition to the inverter-rated insulation (standard across TECO motors), TECO recommends the fitment of a shaft earthing brush and an insulated bearing to mitigate the effects of VSD-induced shaft currents (which can damage the motor bearings). Although quoted as additional costs, protection against VSD-induced shaft currents can only be ensured if an insulated bearing and a shaft earthing brush are installed. Whilst there are different recommendations provided by the IEC, NEMA, CSA and other standards or industry bodies, TECO refers to IEC60034-17 and IEC60034-25 and recommends the following:

- All installations must be done in accordance with IEC60034-17 and IEC60034-25.**
- Rotor Groundary brush on the drive-end and insulated bearing (or insulated housing) on the non-drive-end for frames 280 and above.**
- Setting the VSD carrier frequency (switching frequency) to 5kHz or below (as higher switching frequencies might increase shaft currents).**

Alternatively, the user may wish to specify a common mode voltage filter, to be installed at the VSD output and effectively eliminate common mode voltages which are the root cause of VSD-induced shaft currents.

Typical "VSD Ready" Large Frame Size Motor

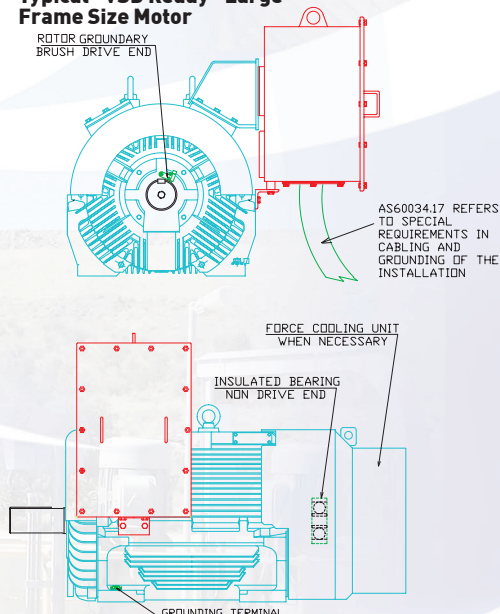

"Rotor Groundary Brush" fitted to D315 frame motor

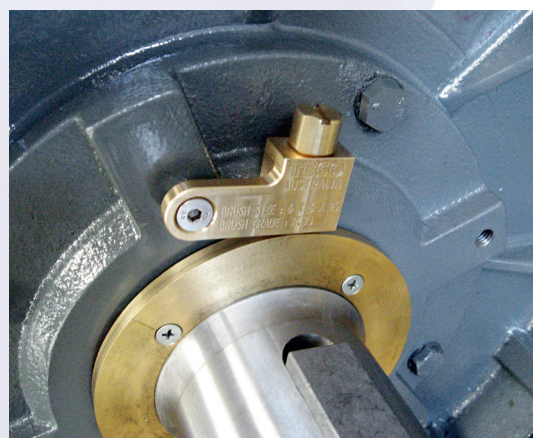



TECO Industry 4.0 Grade





The TECO “Smart Motor MMK” lets you know when things are not quite well with your motor, so that you are in control of maintenance requirements in real time 24/7. The Kit is factory installed or retrofitted. It reports on the machine’s operational status every second on a 24/7 basis, using IoT technology to work remotely with a smart phone providing real-time monitoring and interactive diagnosis, giving you complete peace of mind.

TECOM’s “All-Smart Portable Vibration Diagnosis Instrument” is an IoT ready portable vibration measurement instrument. It contains IoT (Internet of Things) gateway, smart vibration sensors, and a standard mobile power-pack. The gateway connects up to 4 sensors, and its built-in WiFi allows simultaneous use by up to 20 technicians. No subscription required. It is easy to use, simply connect your phone to the WiFi and follow the app screens.

TECO ELECTRIC MOTORS
MOBILE PHONE APP
NOW AVAILABLE



Available on the  App Store 

TECO AUSTRALIA - HOME APPLIANCE DIVISION

Air Conditioning



Kitchen



Laundry



Living



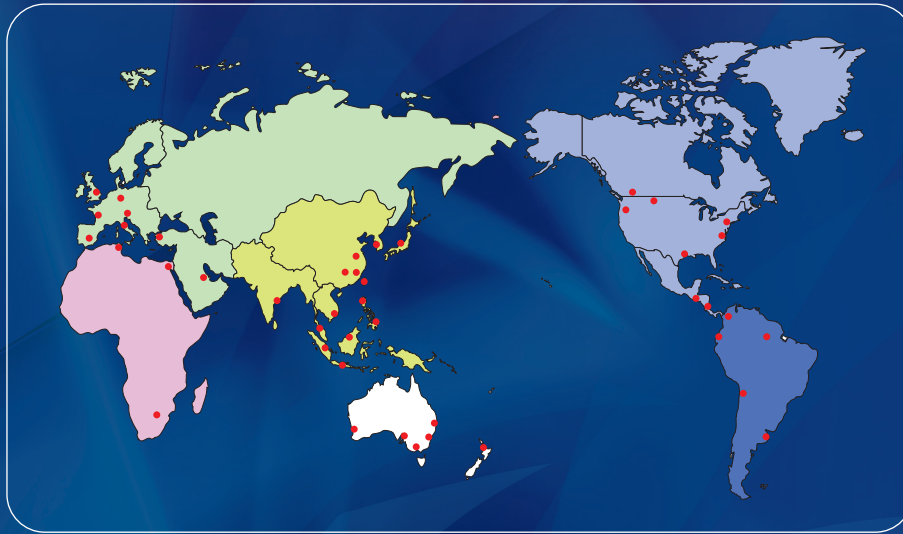

AUSTRALIA - NEW ZEALAND



Head Office, Sydney

TECO Australia Pty Ltd
335-337 Woodpark Road,
Smithfield NSW 2164
Tel: **02 9765 8118**
Fax: **02 9604 9330**



Melbourne

TECO Australia Pty Ltd
16 Longstaff Road,
Bayswater VIC 3153
Tel: 03 9720 4411
Fax: 03 9720 5355



Brisbane

TECO Australia Pty Ltd
50 Murdoch Circuit,
Acacia Ridge QLD 4110
Tel: 07 3373 9600
Fax: 07 3373 9699



Perth

TECO Australia Pty Ltd
18 Hazelhurst Street,
Kewdale WA 6105
Tel: 08 9479 4879
Fax: 08 9478 3876



New Zealand

TECO New Zealand Ltd
Unit 3, 477 Great South Road,
Penrose, Auckland
Tel: 64 9-526 8480
Fax: 64 9-526 8484
sales@teco.co.nz

Distributed by:

www.teco.com.au emd@teco.com.au

The information in this catalogue is subject to change without notice.